

MORRISON AND MARVIN ENGINE WORKS MODEL BUILDERS VISE

\$130 plus \$14 shipping

international no insurance

The vise kit includes all materials and some partially machined pieces. Additional machining required.

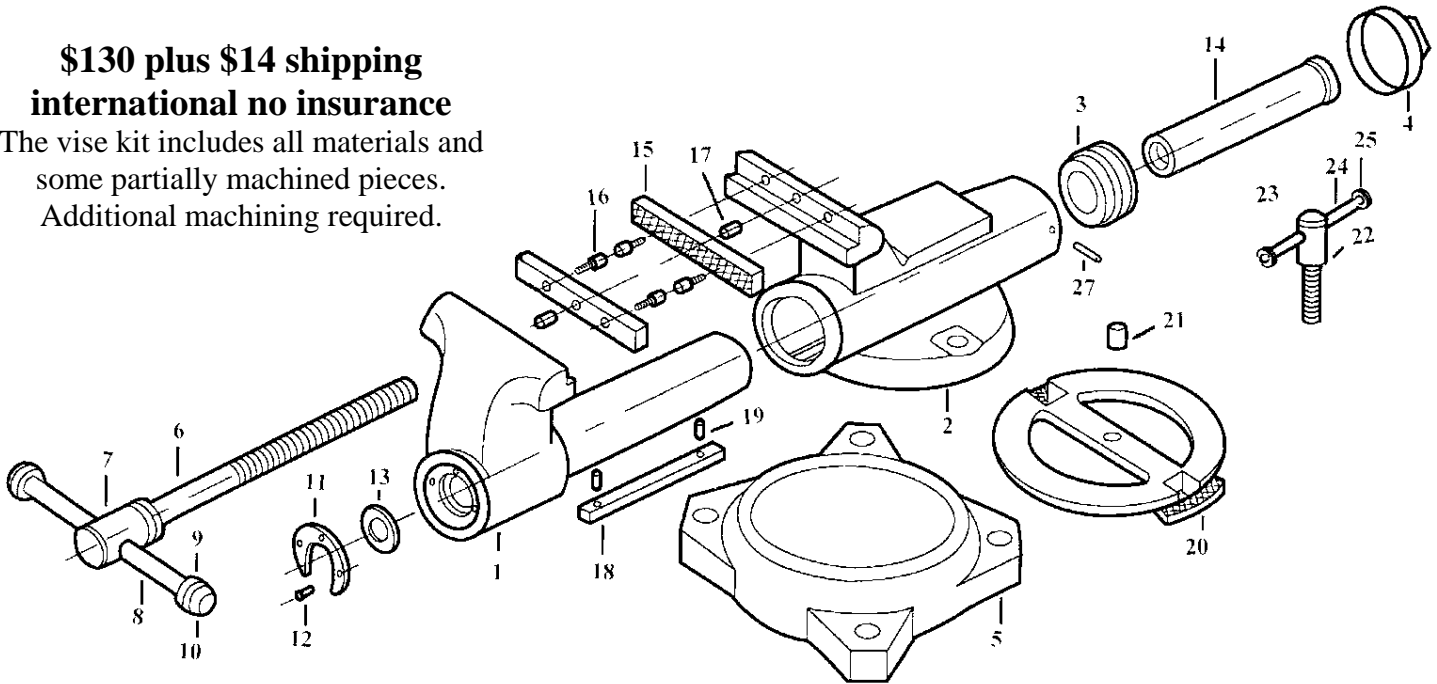

Made in USA

Part #	Description	QU	Material	Part #	Description	QU	Material
1	Movable Vise Jaw	1	4140	15	Replaceable Jaws	2	W1 Tool Steel
2	Vise Body	1	4140	16	Jaw Screws	4	18 - 8SS
3	Acme Nut Holder	1	4140	17	Jaw Alignment Pins	2	18 - 8SS
4	End Cap	1	4140	18	Key	1	W1 Tool Steel
5	Swivel Base	1	4140	19	Key Rollpins	2	Steel
6	Acme Screw 1/4-16	1	C1215	20	Swivel Plate	1	12L14
7	Screw End	1	12L14	21	Swivel Pin	1	Alloy Steel
8	Handle	1	W1 Tool Steel	22	Lock Bolts	2	Alloy Steel
9	Handle Cushion	2	EDPM	23	Lock Bolt Nuts	2	12L14
10	Handle End	2	Steel	24	Lock Handle	2	18 - 8SS
11	Acme Screw Retainer	1	Steel	25	Lock Handle Ends	4	18 - 8SS
12	Retainer Screws	3	18 - 8SS	26	Acme Nut Cushion	1	EDPM
13	Thrust Washer	1	Steel	27	Acme Nut Locking Pin	1	18 - 8SS
14	Acme Nut	1	360 Brass				

Call for availability of finished vise

Heavy Duty Swivel Base Model Builders Vise

Quarter Scale of a 4 1/2" vise, jaw 1 1/8" wide, throat 1 3/4", height 2 1/2", length 4 1/2" This vise was designed not only as a replica of the older styles of machinist vises but also a useful working vise for your bench! The castings are tool steel and the acme screw, nut, and vise jaws are partially machined. A machinist with minimum tools, lathe and drill press, can produce a precision working vise.

MORRISON AND MARVIN ENGINE WORKS

P.O. Box 555
Benton City, WA 99320
Phone: (509) 588-3829

www.MorrisonandMarvin.com

EngineShop@MorrisonandMarvin.com