

MILL VISE

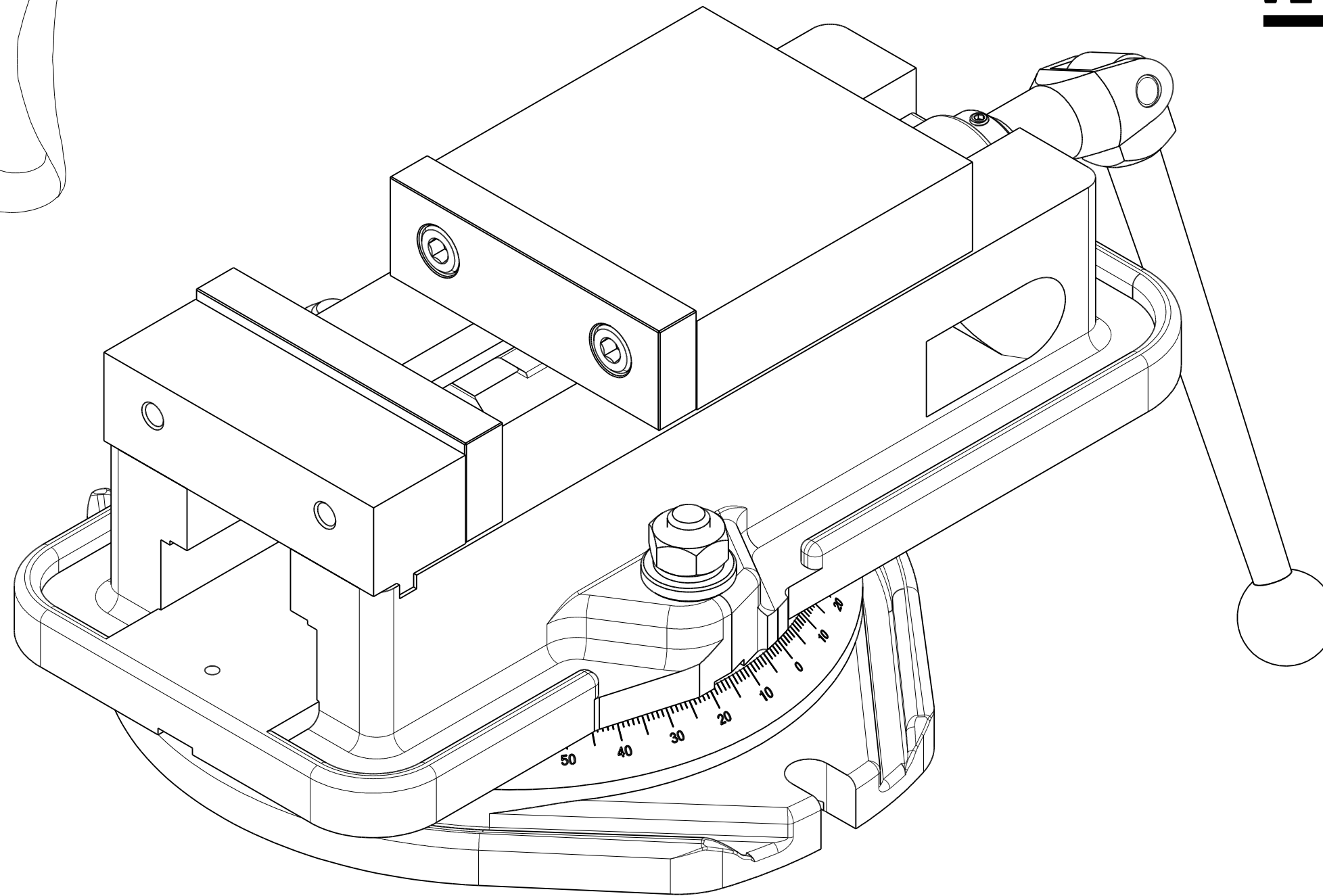

Made in USA

Download a full set of drawings from
MorrisonandMarvin.com

MORRISON & MARVIN ENGINE WORKS

Box 555 Benton City, WA 99320 USA

DESIGNED BY Roland Morrison / Marvin Hedberg		DESCRIPTION Vise Assembly		
DRAWN BY Dave Otto	DATE 1/7/2018			
MATERIAL	SIZE B	SCALE 4:1	SHEET 1 of 18	REV 1

MILL VISE

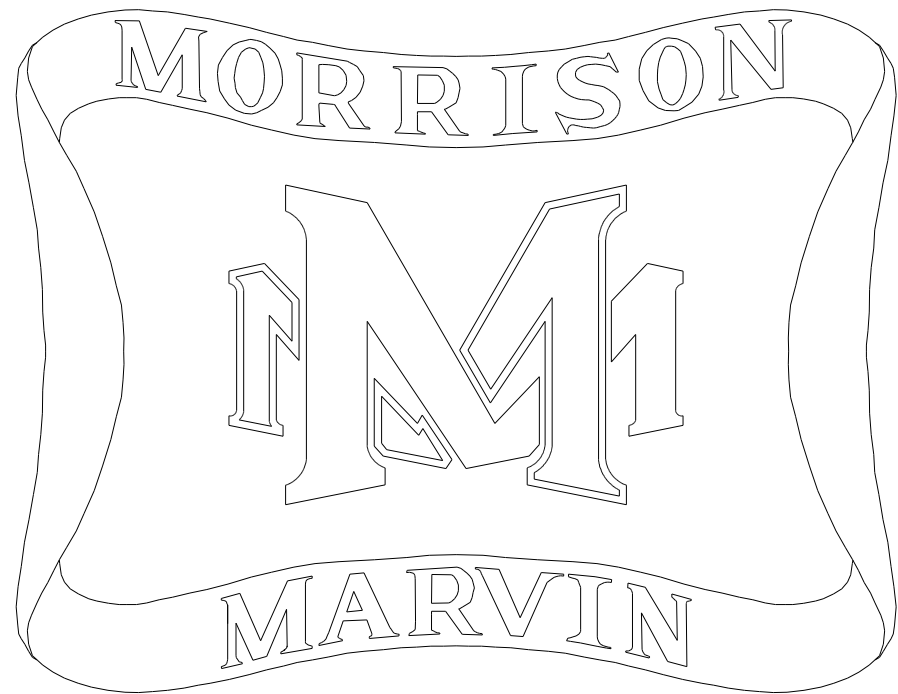
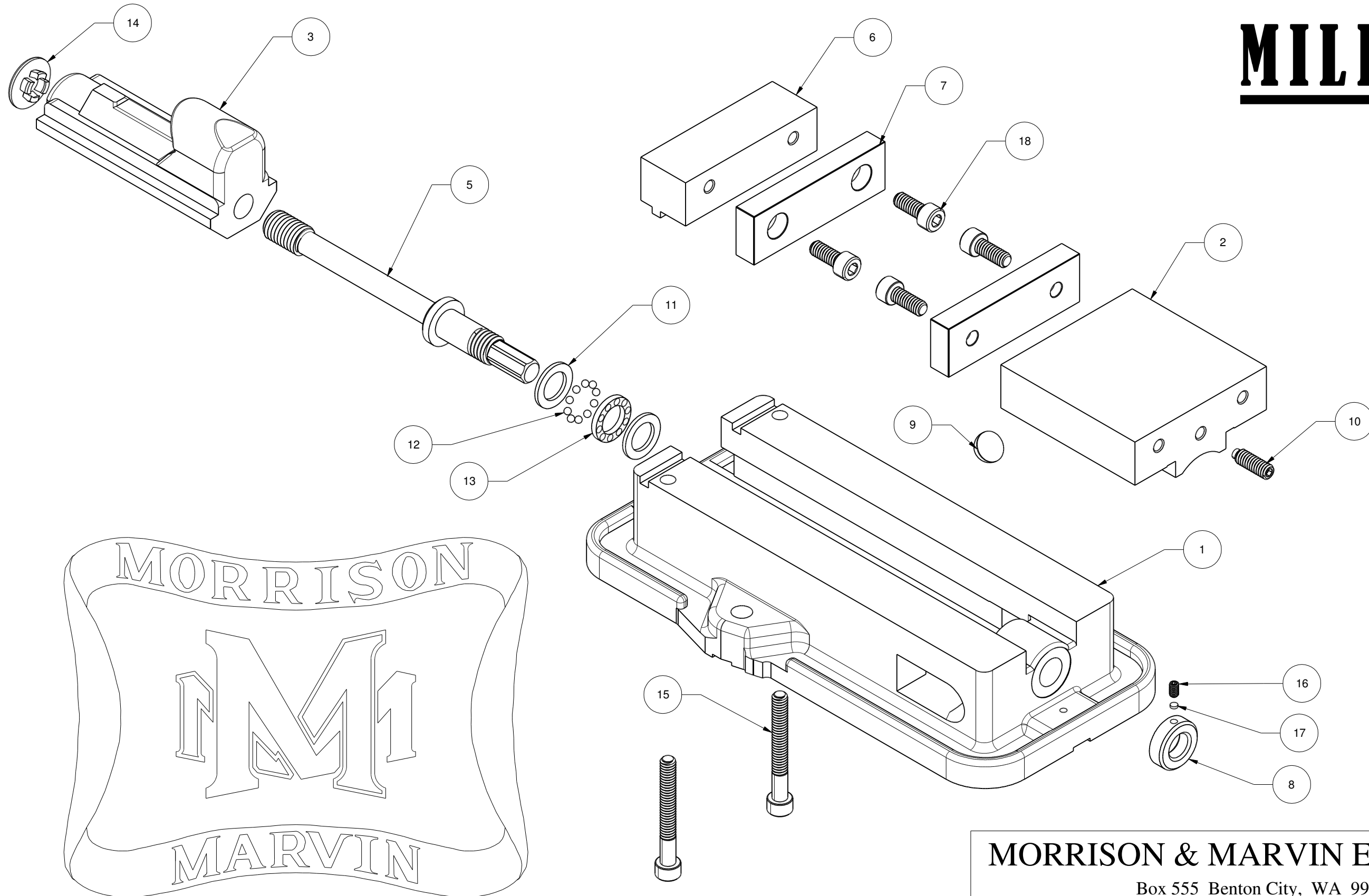

Made in USA

Download a full set of drawings from
MorrisonandMarvin.com

MORRISON & MARVIN ENGINE WORKS

Box 555 Benton City, WA 99320 USA

DESIGNED BY Roland Morrison / Marvin Hedberg		DESCRIPTION Mill Vise Exploded		
DRAWN BY Dave Otto	DATE 1/7/2018	SCALE 1.25:1		SHEET 2 of 18
MATERIAL		SIZE B	SCALE 1.25:1	REV 1

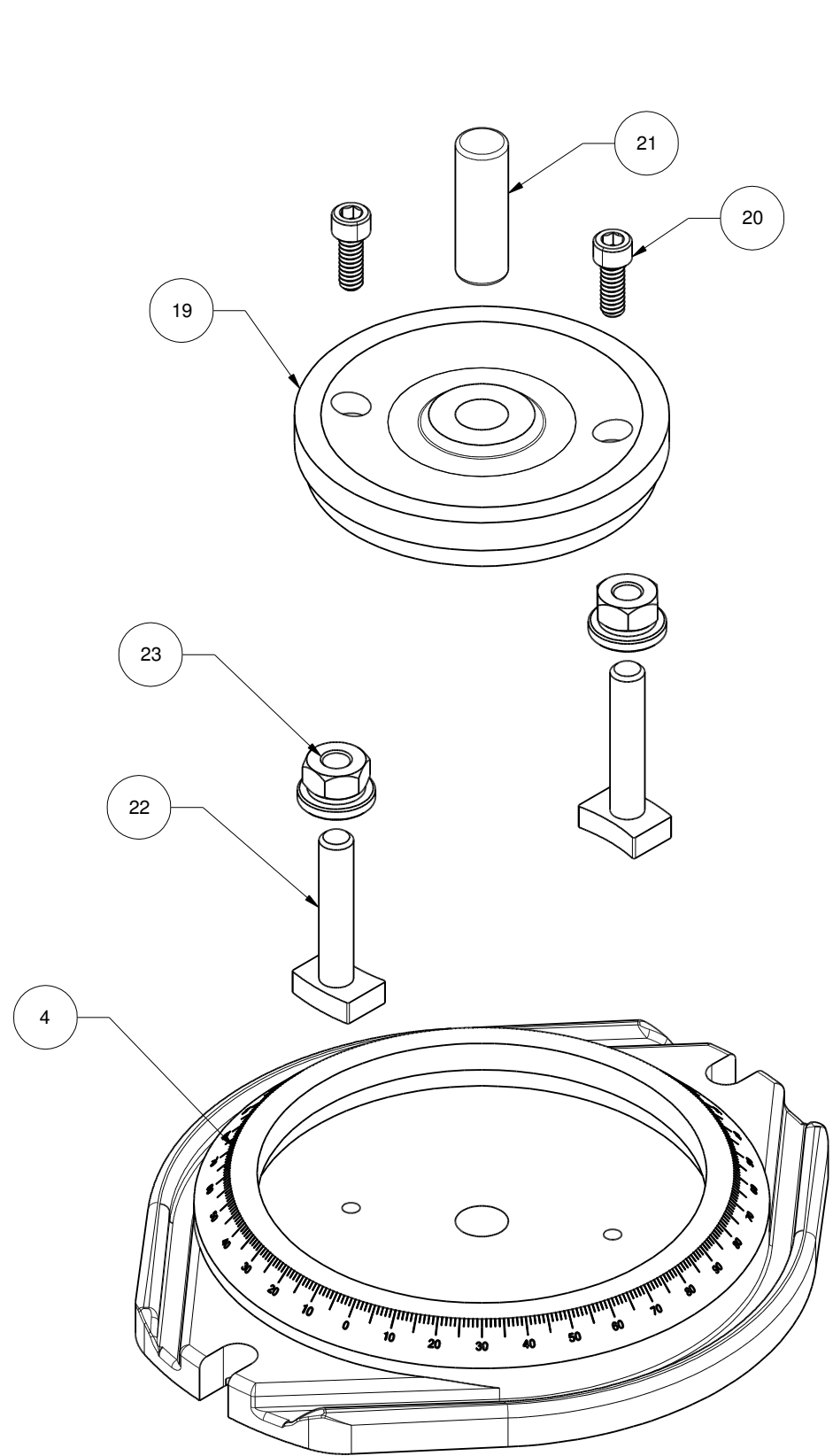

Scale 1.25:1

Made in USA

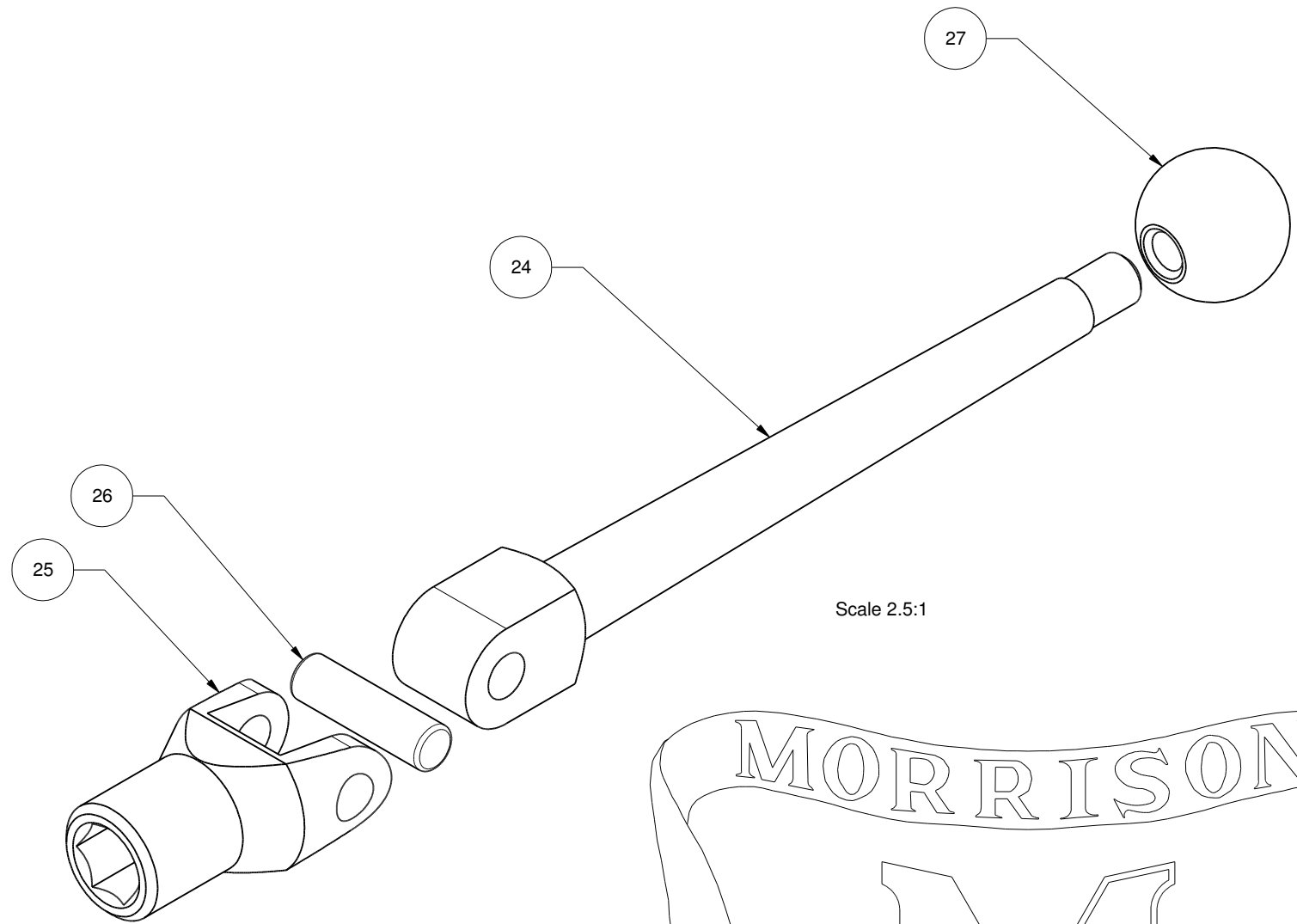

Scale 2.5:1



MILL VISE

MORRISON & MARVIN ENGINE WORKS

Box 555 Benton City, WA 99320 USA

DESIGNED BY Roland Morrison / Marvin Hedberg		DESCRIPTION Mill Vise Exploded		
DRAWN BY Dave Otto	DATE 1/7/2018	SCALE		REV 1
MATERIAL		SIZE B	SHEET 3 of 18	

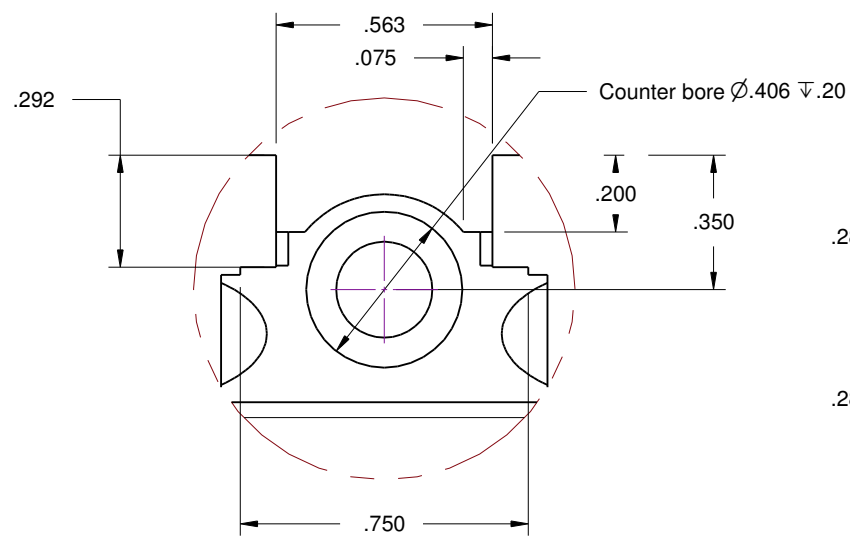

Detail A

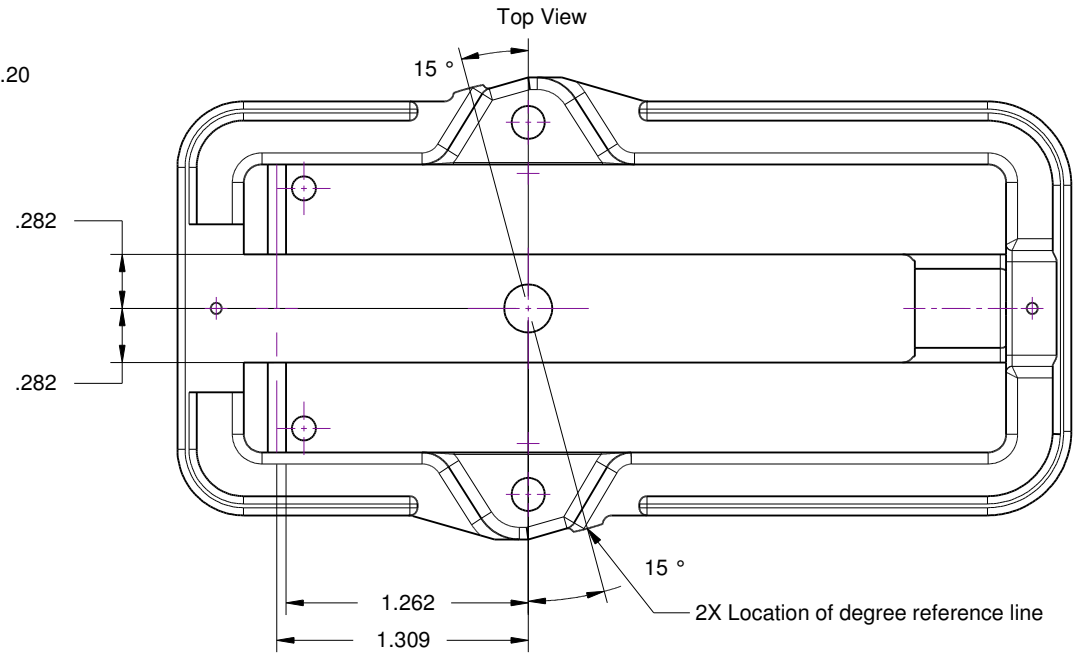

Hidden lines removed for clarity

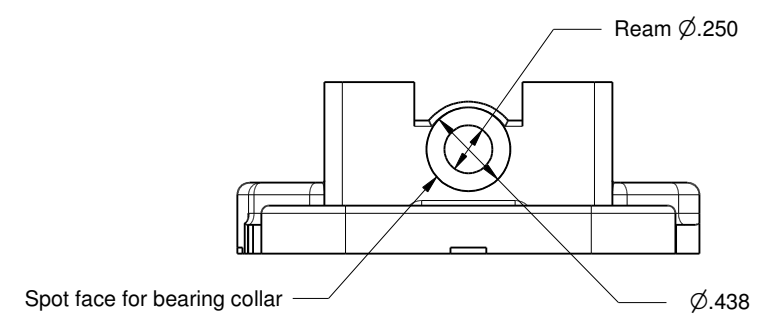
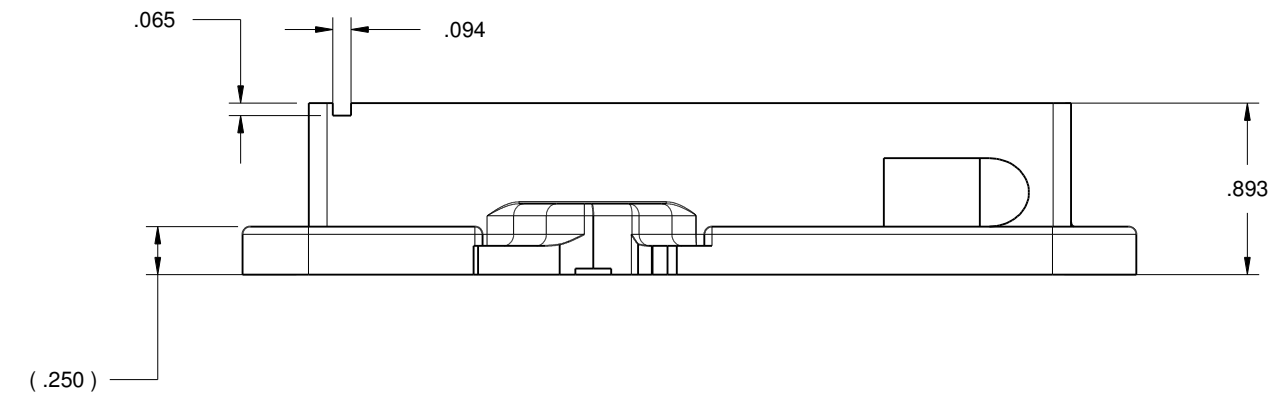
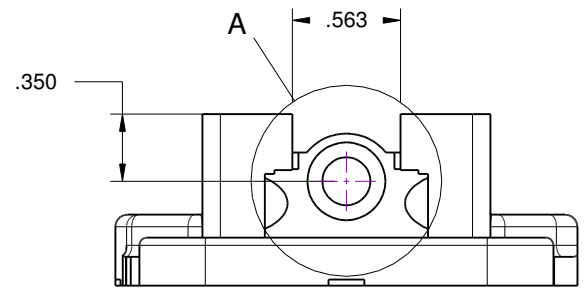
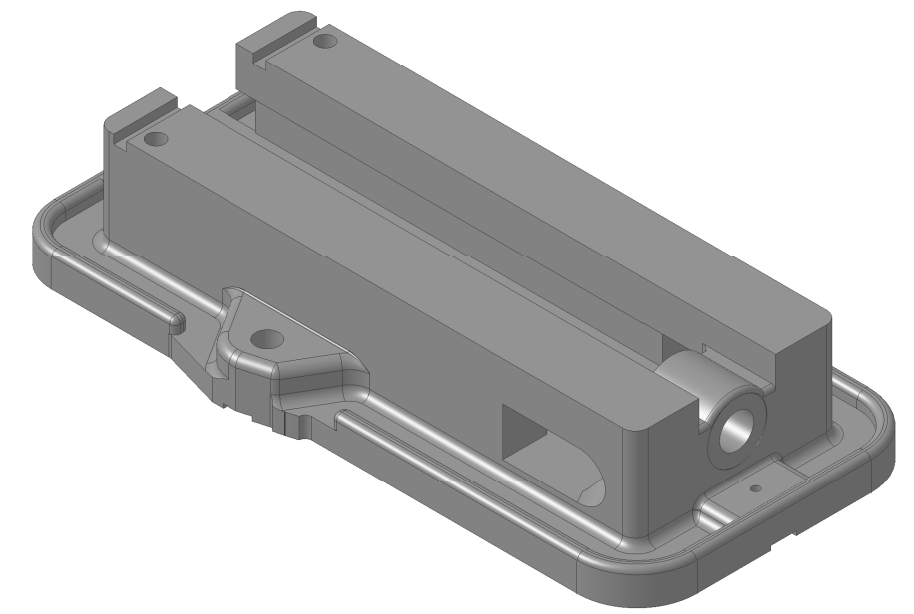

MILL VISE

MORRISON & MARVIN ENGINE WORKS				
Box 555 Benton City, WA 99320 USA				
DESIGNED BY Roland Morrison / Marvin Hedberg		DESCRIPTION #D15-1 Body		
DRAWN BY Dave Otto	DATE 1/7/2018			
MATERIAL 4140 Steel Casting	SIZE B	SCALE 1 : 1	SHEET 4 of 18	REV 1

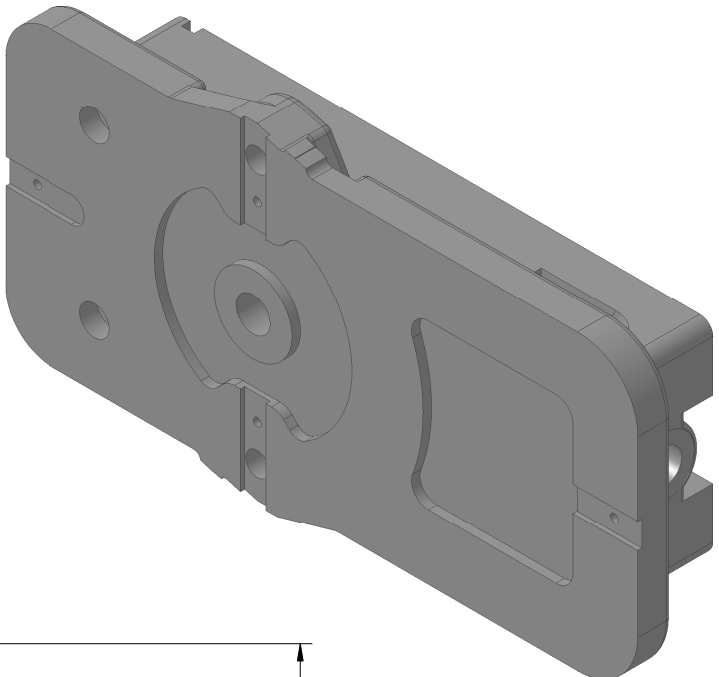
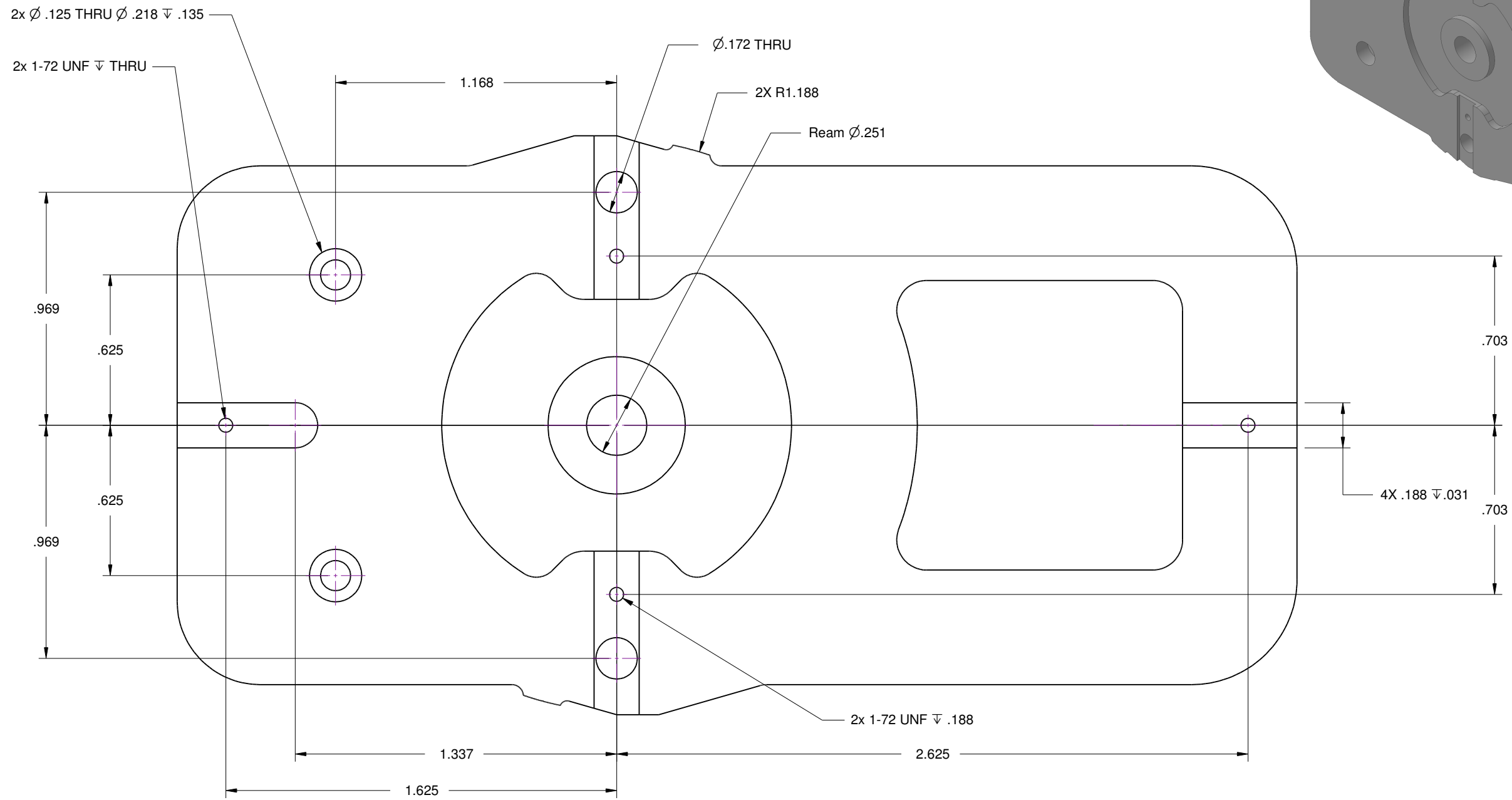

ISO View 1: 1

Bottom View

Hidden lines removed for clarity

MILL VISE

MORRISON & MARVIN ENGINE WORKS					
Box 555 Benton City, WA 99320 USA					
DESIGNED BY Roland Morrison / Marvin Hedberg			#D15-1 Body		
DRAWN BY Dave Otto		DATE 1/7/2018			
MATERIAL 4140 Steel Casting	SIZE B	SCALE 2 : 1	SHEET 5 of 18	REV 1	

Refer to machining notes;

- 1: All interior cast surfaces need to remain square and parallel to outside edges.
- 2: To insure proper location of nut approximately .06 of material needs to be removed from the bottom surface of the casting, when machining bottom features.
Failure to do this may also cause the top surface to break through into the cavity when the top is brought to proper thickness.

Break sharp corner with file approximately .03 radius

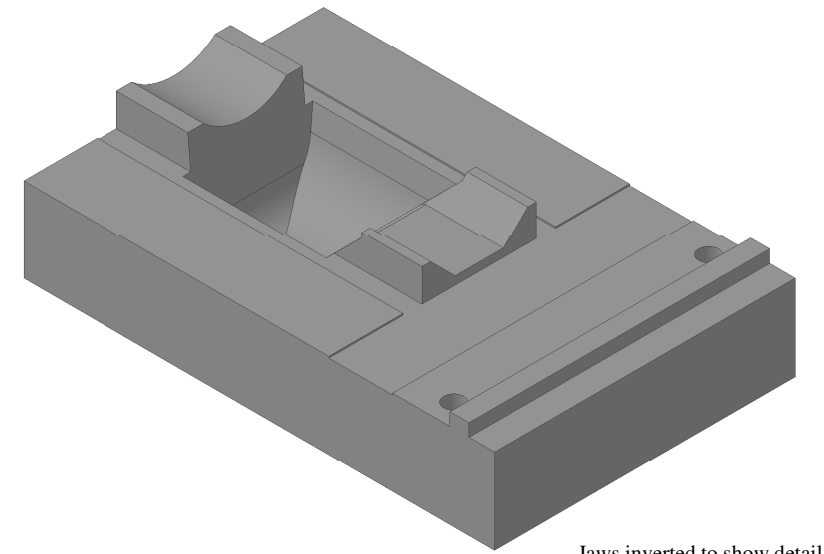
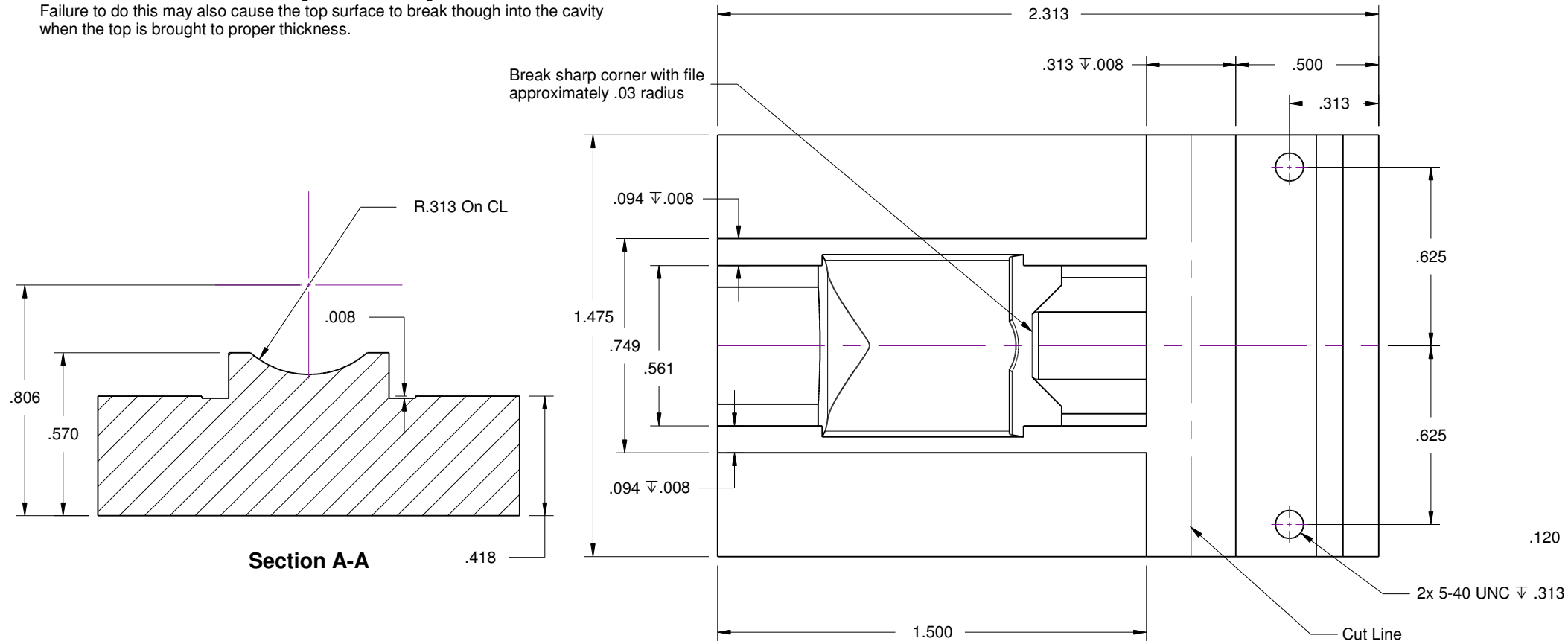

Jaws inverted to show detail

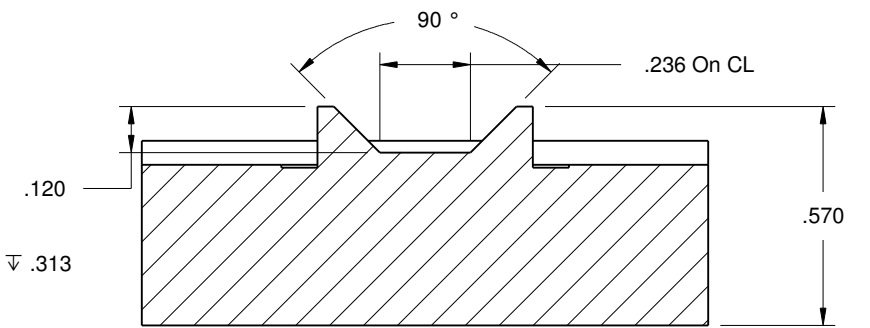

Section B-B

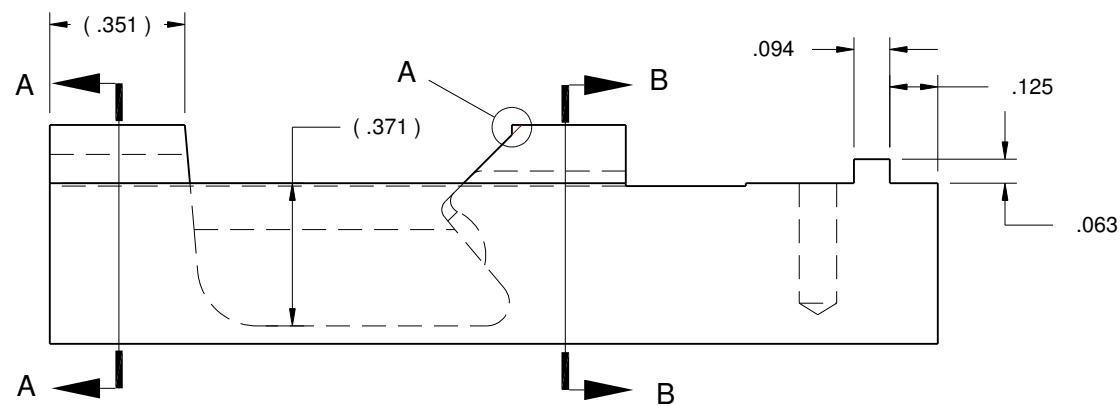
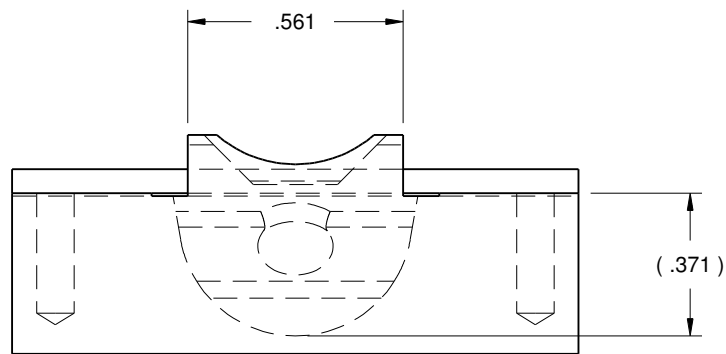

File or machine square corner to blend with casting taper

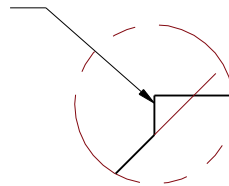

Detail A

MILL VISE

MORRISON & MARVIN ENGINE WORKS

Box 555 Benton City, WA 99320 USA

DESIGNED BY Roland Morrison / Marvin Hedberg		DESCRIPTION #D15-2 & #D15-6 Jaw Casting		
DRAWN BY Dave Otto	DATE 1/7/2018			
MATERIAL 4140 Steel Casting	SIZE B	SCALE 2:1	SHEET 6 of 18	REV 1

#D15-2 Movable Jaw
Scale 2X

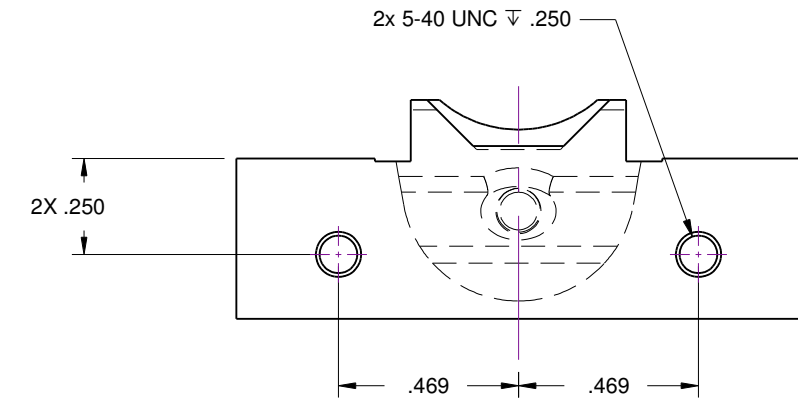
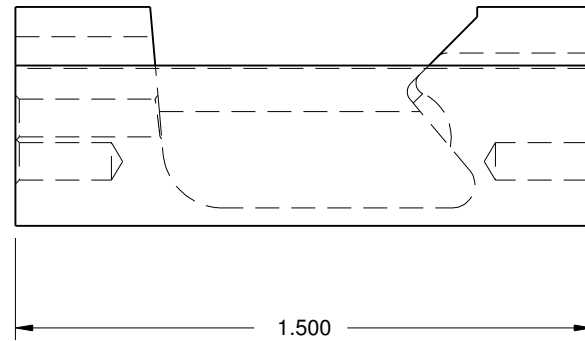
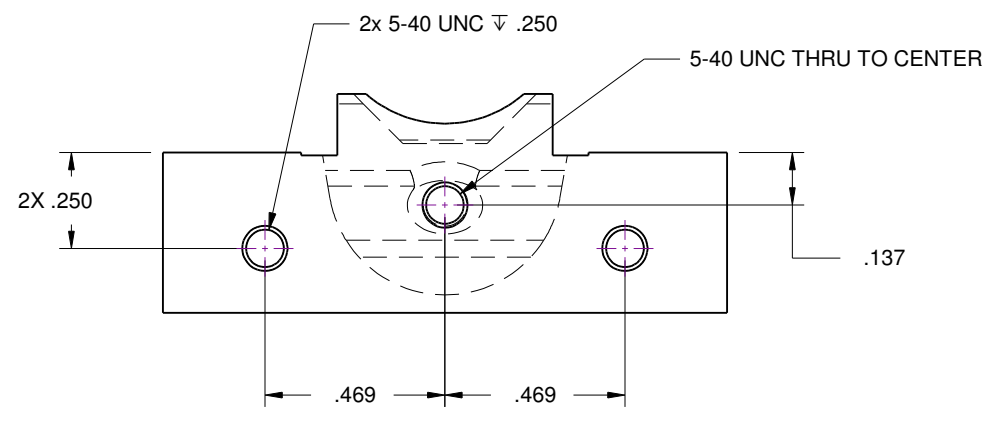

#D15-9 Spherical Segment
Scale 6X
Tool Steel; heat treat and leave full hard

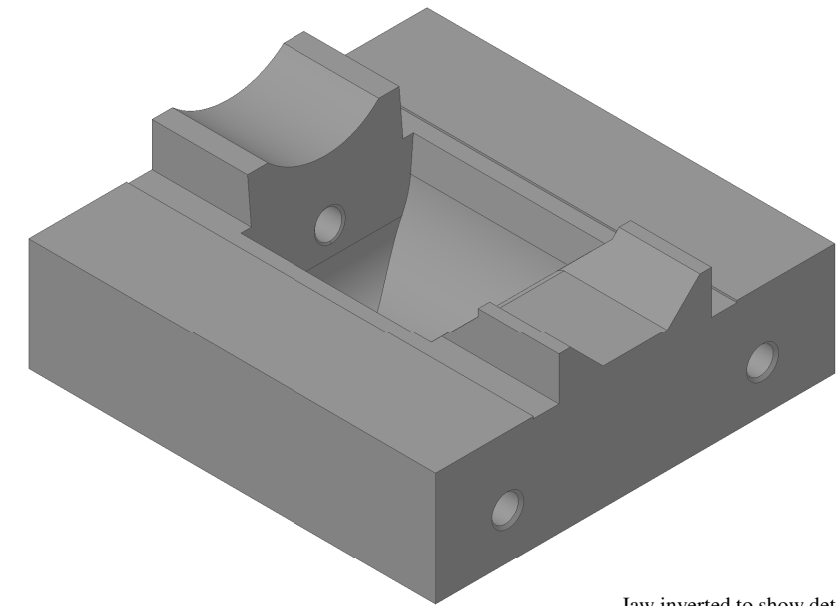
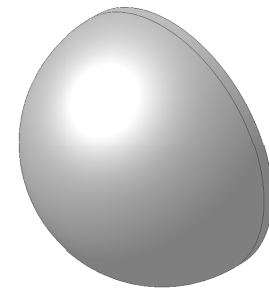
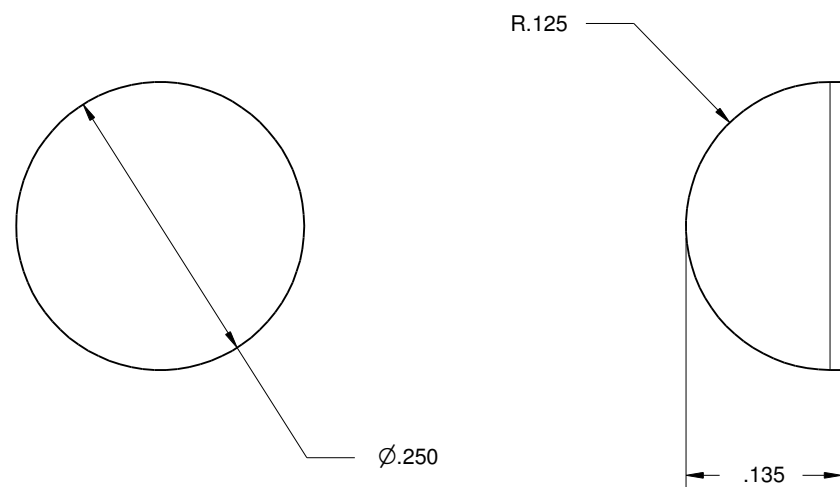

Jaw inverted to show detail

MILL VISE

MORRISON & MARVIN ENGINE WORKS

Box 555 Benton City, WA 99320 USA

DESIGNED BY Roland Morrison / Marvin Hedberg		DESCRIPTION Movable Jaw & Segment		
DRAWN BY Dave Otto	DATE 1/7/2018	MATERIAL		REV 1
SIZE B	SCALE	SHEET 7 of 18		

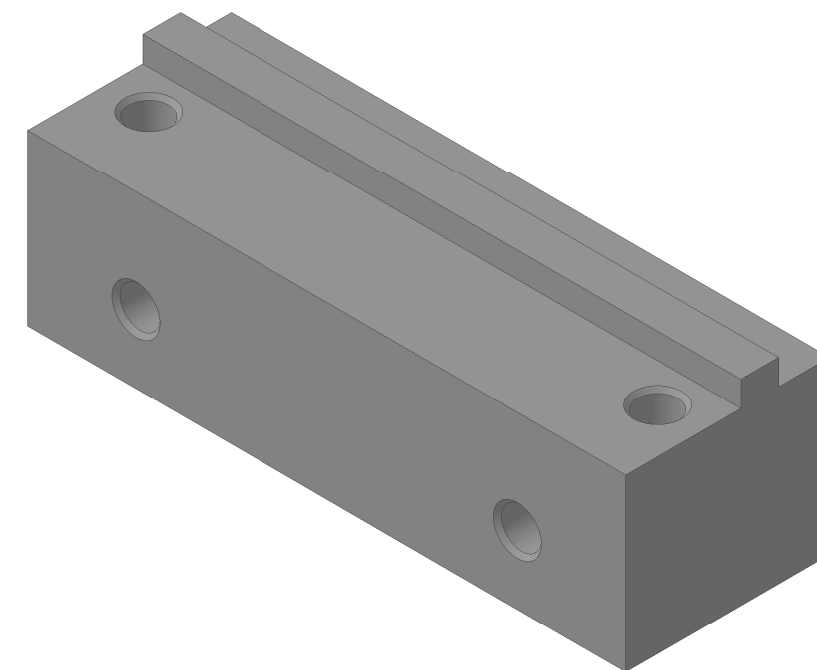
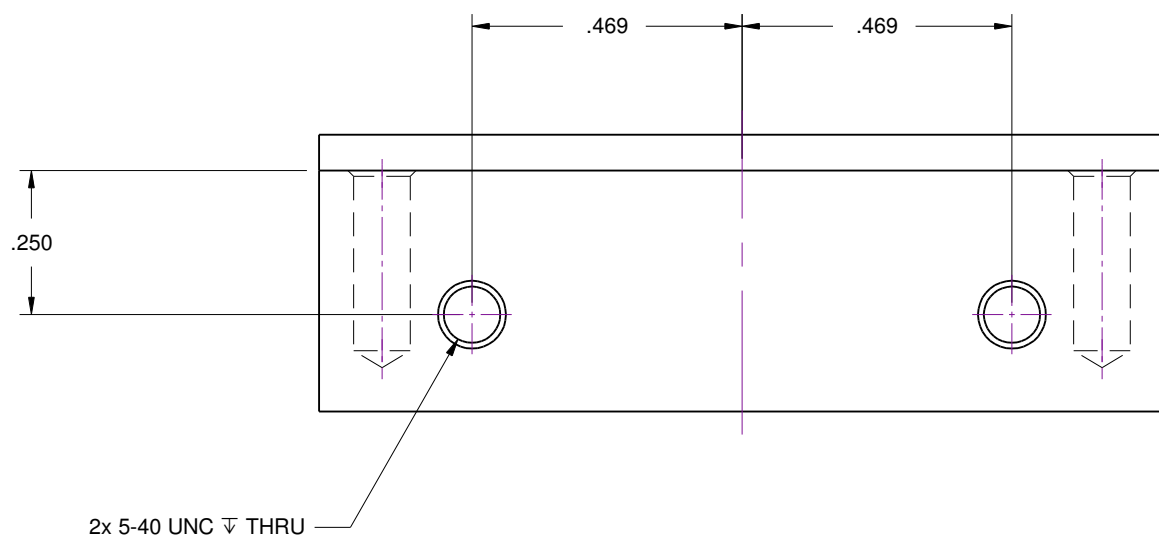
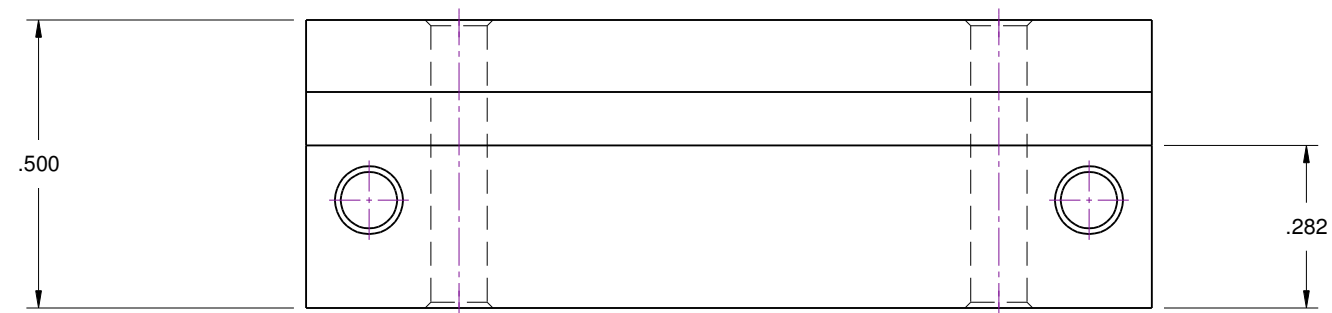

Jaw inverted to show detail

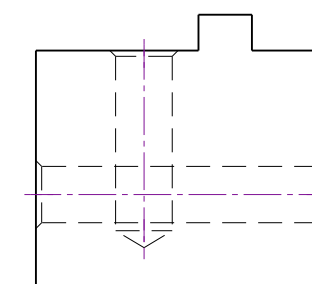

MILL VISE

MORRISON & MARVIN ENGINE WORKS

Box 555 Benton City, WA 99320 USA

DESIGNED BY Roland Morrison / Marvin Hedberg		DESCRIPTION #D15-6 Stationary Jaw		
DRAWN BY Dave Otto	DATE 1/7/2018			
MATERIAL 4140 Steel Casting	SIZE B	SCALE 3:1	SHEET 8 of 18	REV 1

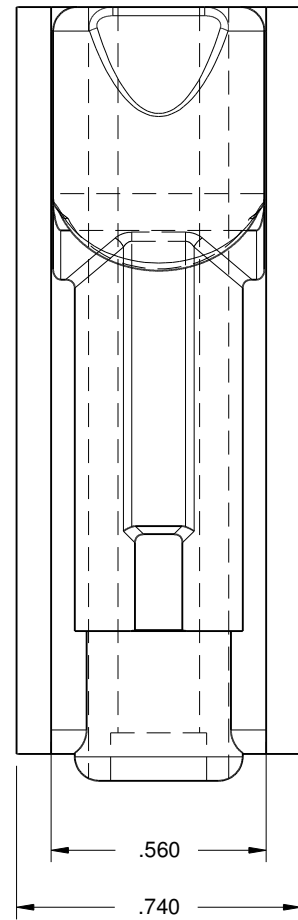

This surface may need to be filed for clearance in the #D15-2 moveable jaw, check at assembly

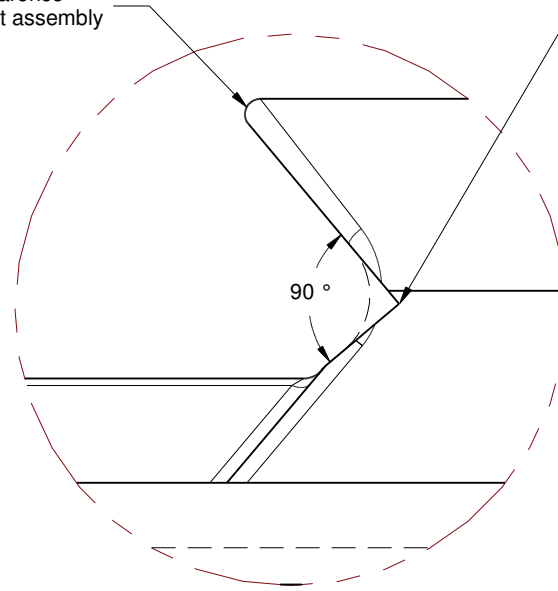

Remove cast radius from this area to square up these two surfaces.

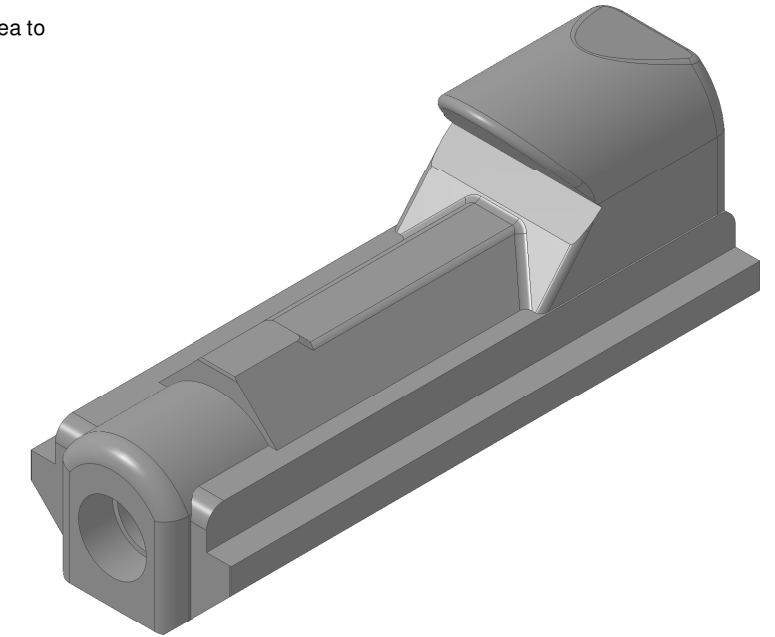

Detail A

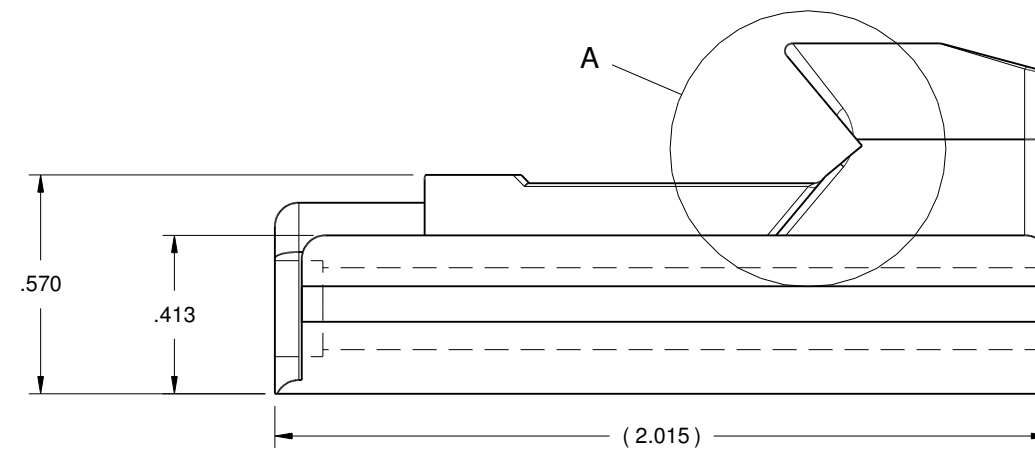
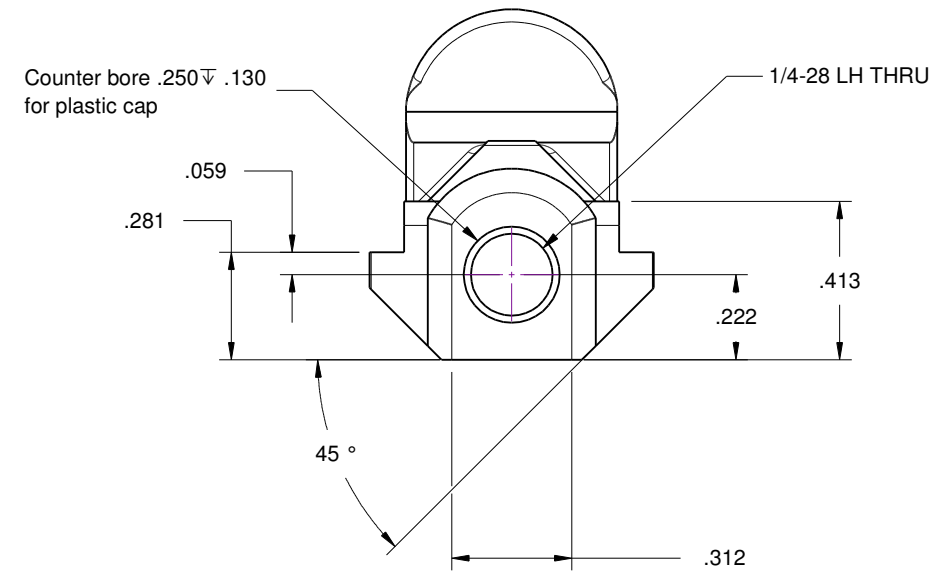

MILL VISE

MORRISON & MARVIN ENGINE WORKS

Box 555 Benton City, WA 99320 USA

DESIGNED BY Roland Morrison / Marvin Hedberg		DESCRIPTION #D15-3 Nut		
DRAWN BY Dave Otto	DATE 1/7/2018			
MATERIAL 4140 Steel Casting	SIZE B	SCALE 2:1	SHEET 9 of 18	REV 1

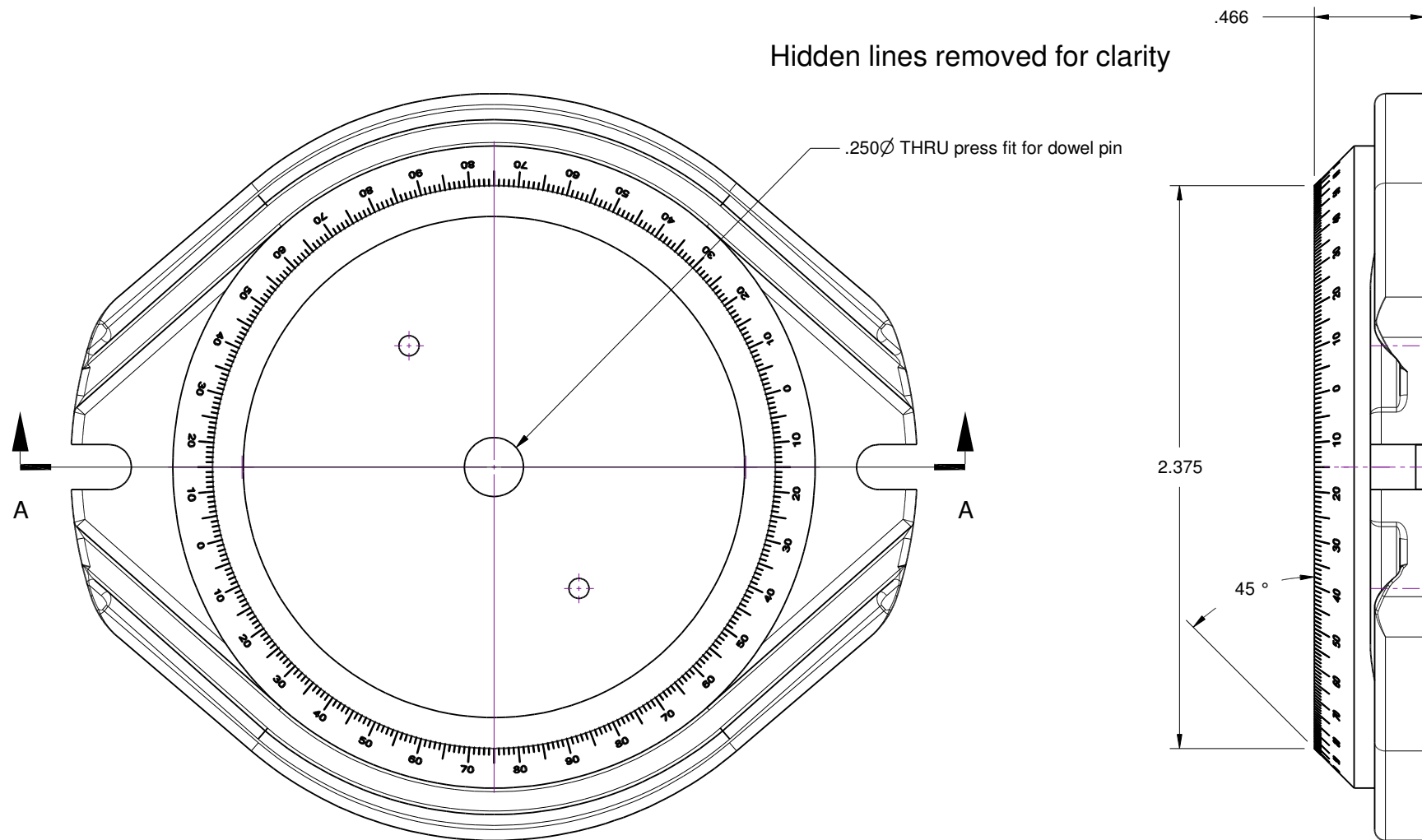
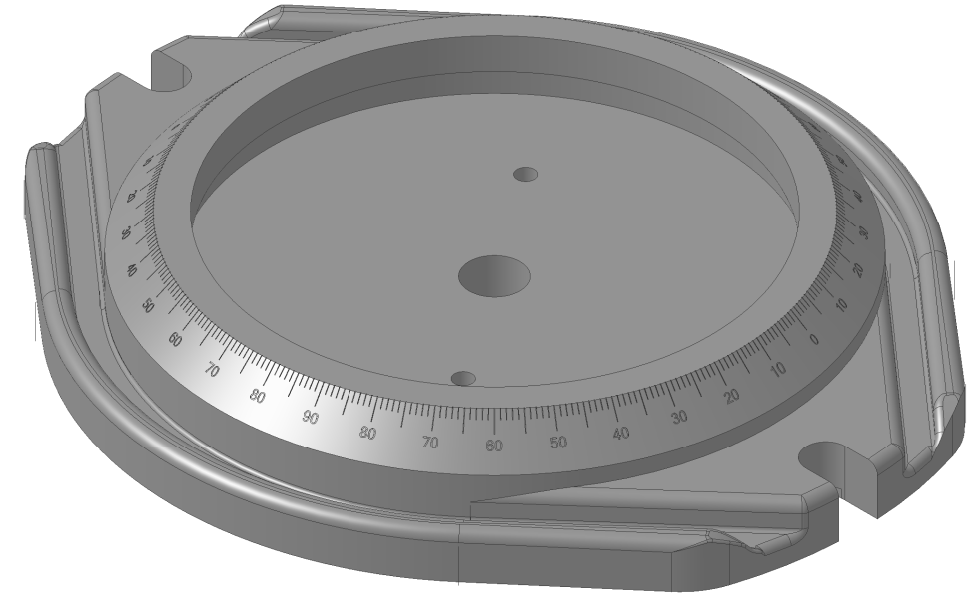
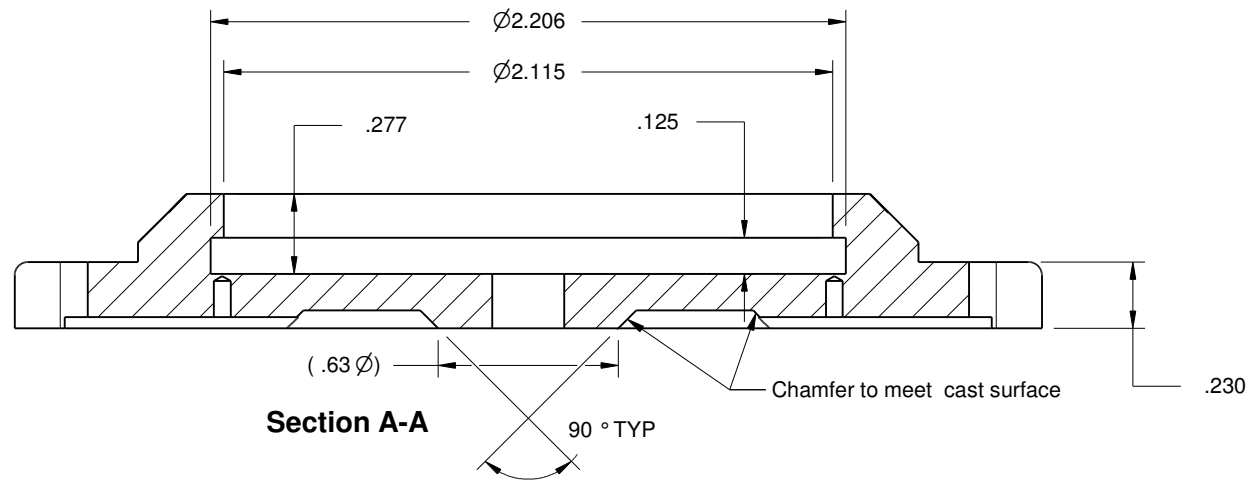

MILLVISE

MORRISON & MARVIN ENGINE WORKS

Box 555 Benton City, WA 99320 USA

DESIGNED BY Roland Morrison / Marvin Hedberg		DESCRIPTION #D15-4 Swivel Base		
DRAWN BY Dave Otto	DATE 1/7/2018			
MATERIAL	SIZE B	SCALE 1.5:1	SHEET 10 of 18	REV 1

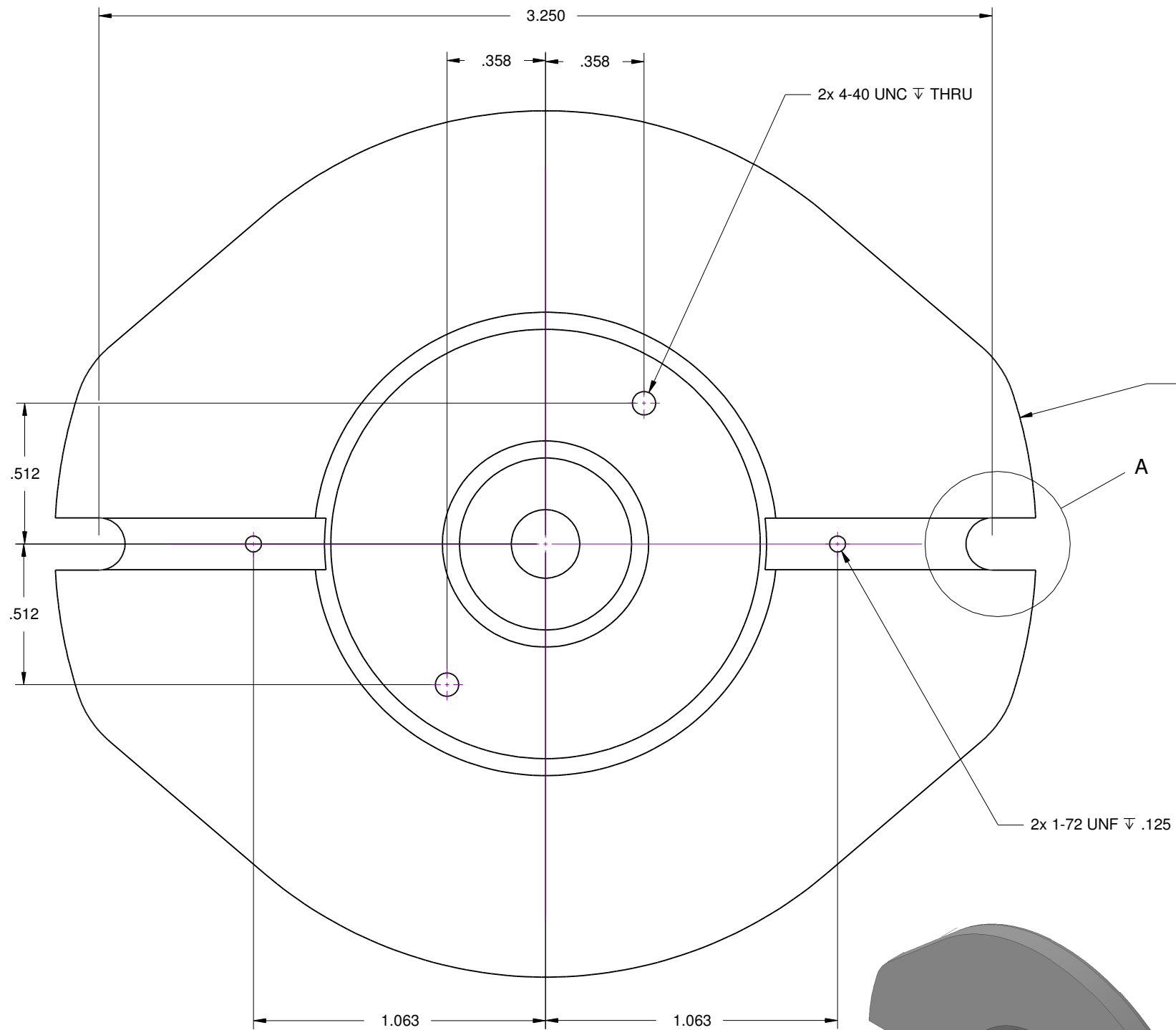

Hidden lines removed for clarity

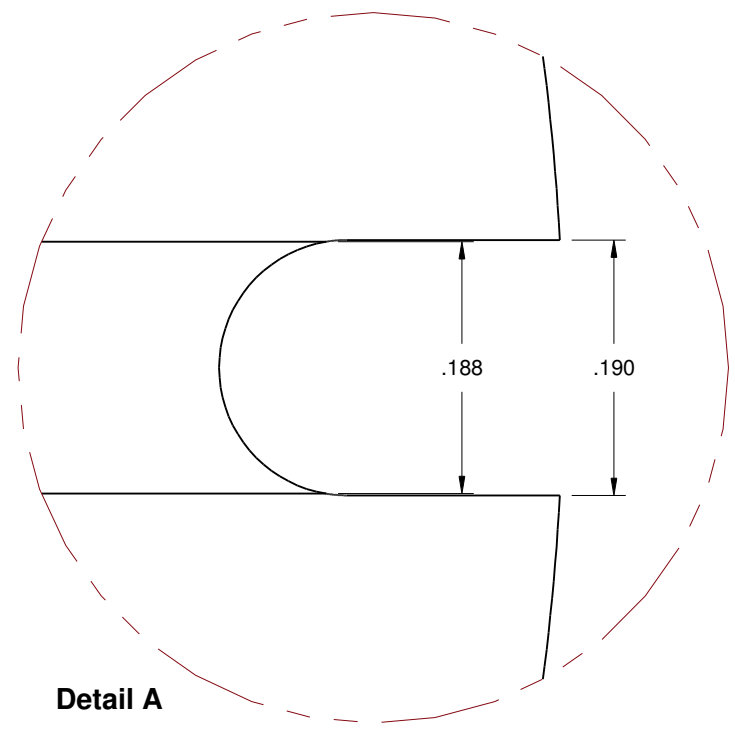
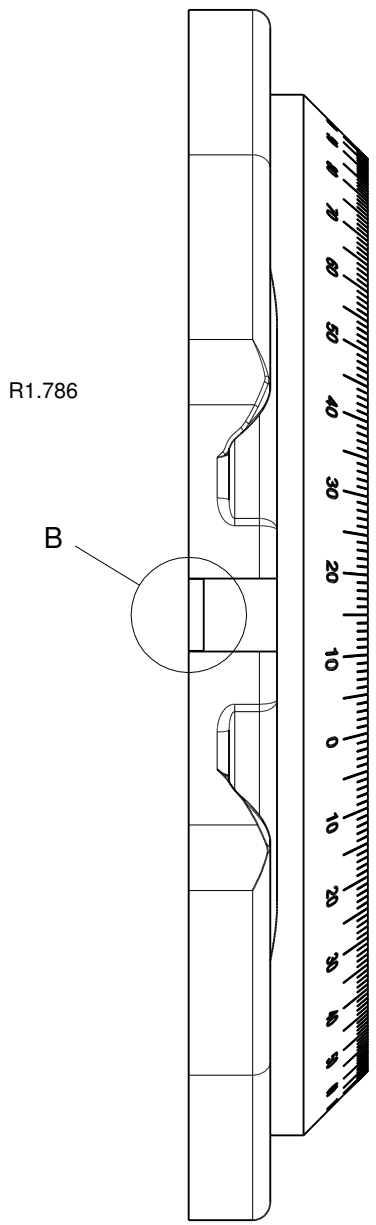
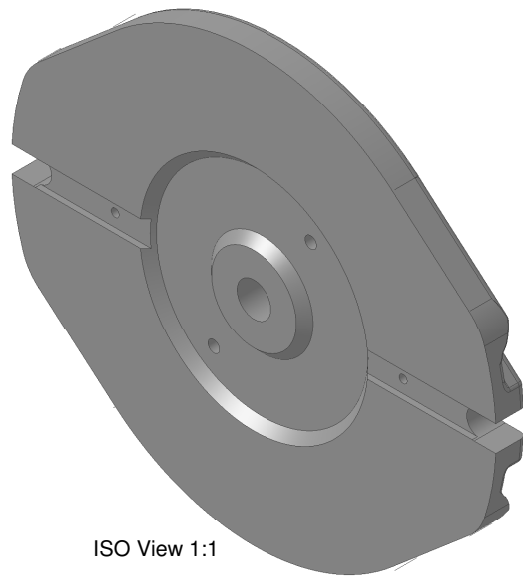

Detail A

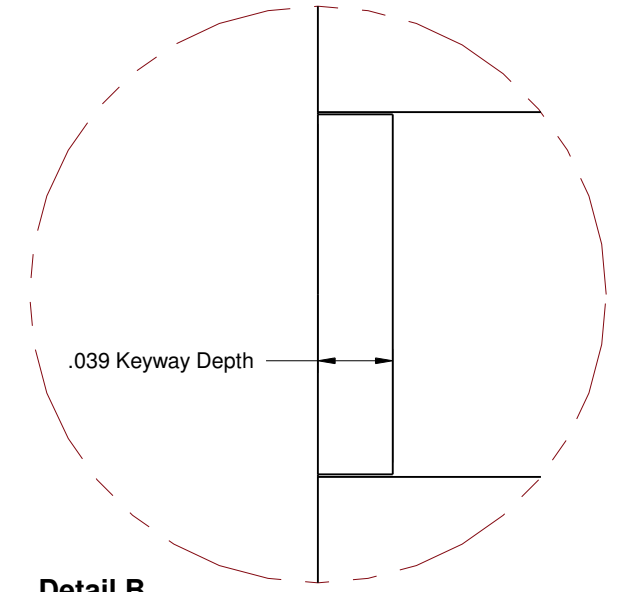

Detail B

MILL VISE

MORRISON & MARVIN ENGINE WORKS

Box 555 Benton City, WA 99320 USA

DESIGNED BY Roland Morrison / Marvin Hedberg		DESCRIPTION #D15-4 Swivel Base		
DRAWN BY Dave Otto	DATE 1/7/2018			
MATERIAL 4140 Steel Casting	SIZE B	SCALE 1.5:1	SHEET 11 of 18	REV 1

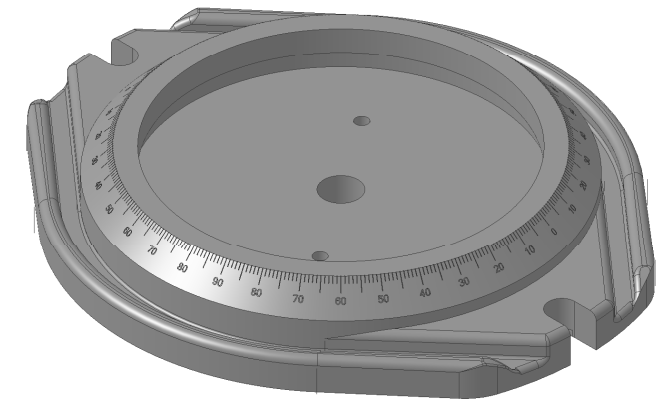
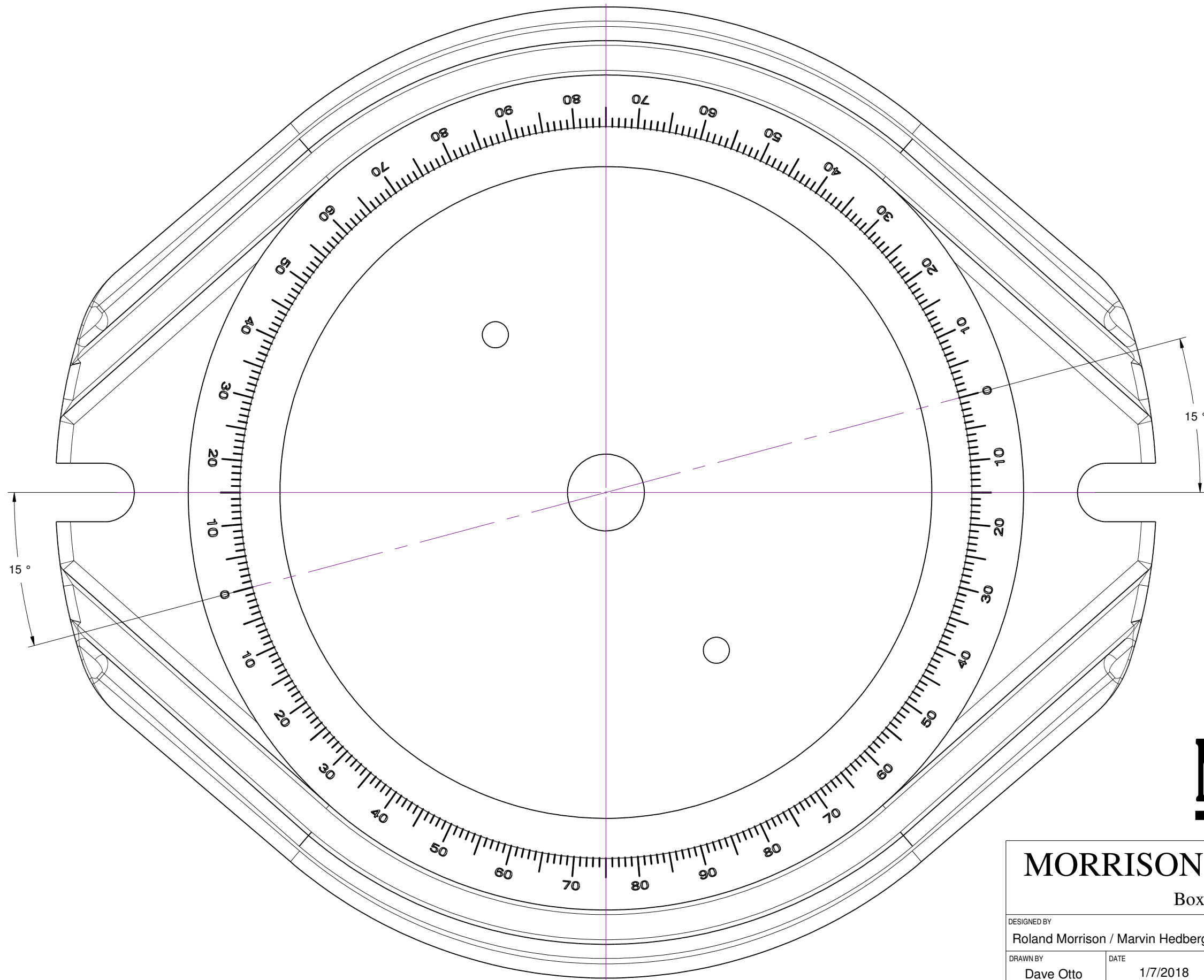

ISO view 1:1

Engrave as shown:
 10 degree lines .09 long
 1 degree lines .04 long
 Numbers may be stamped with .06 letter stamps,
 or engraved .04 letter height.
 Use previously machined keyways on bottom for alignment.

15°

15°

MILLVISE

MORRISON & MARVIN ENGINE WORKS

Box 555 Benton City, WA 99320 USA

DESIGNED BY Roland Morrison / Marvin Hedberg		DESCRIPTION #D15-4 Swivel Base		
DRAWN BY Dave Otto	DATE 1/7/2018			
MATERIAL 4140 Cast Steel	SIZE B	SCALE 3:1	SHEET 12 of 18	REV 1

#D15-19 Swivel Center
Scale 2:1

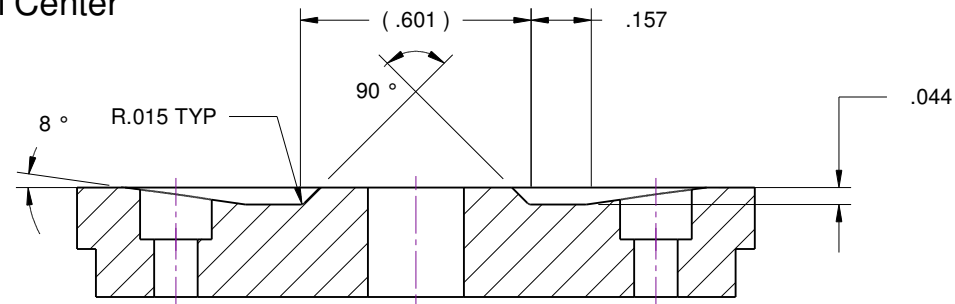

Section A-A

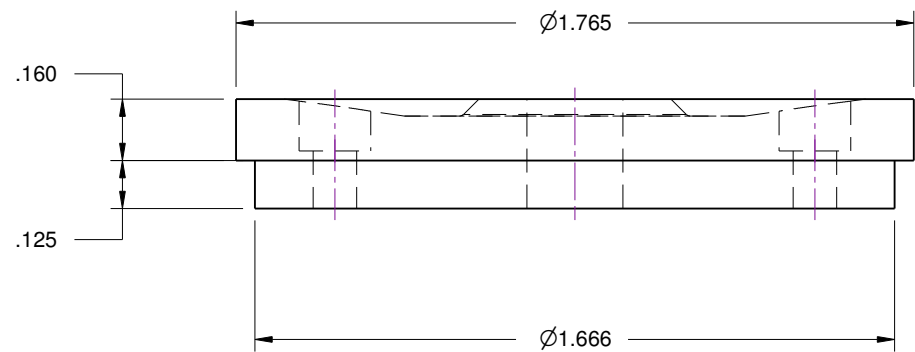
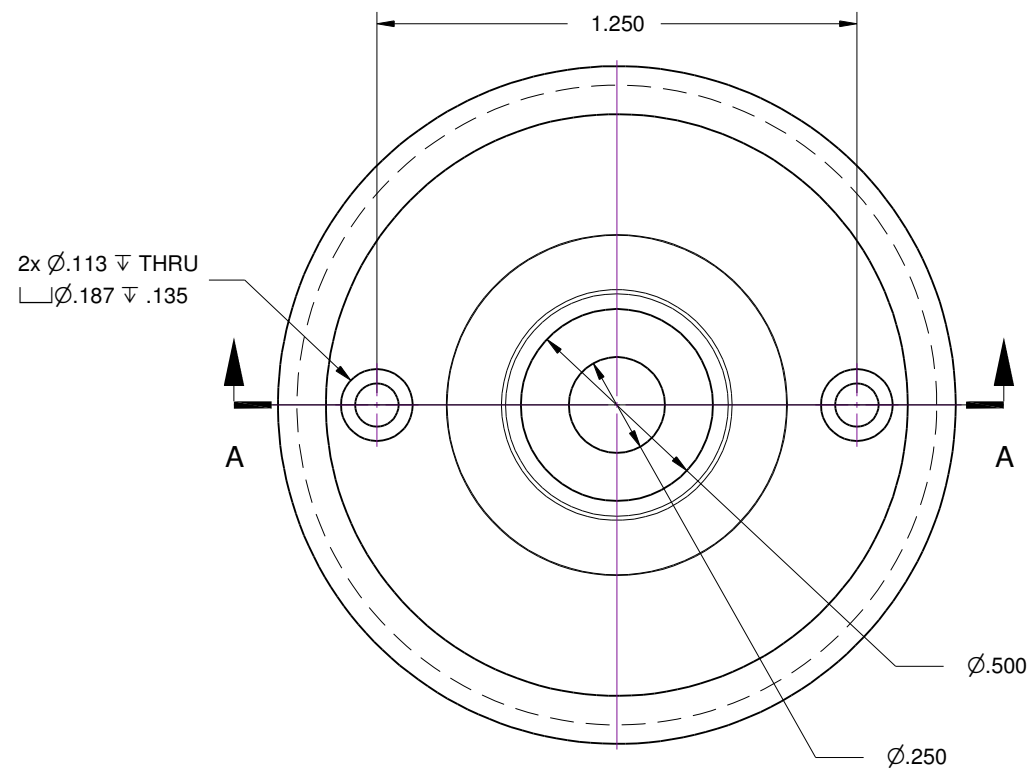

#D15-22 Swivel Bolt
Scale 3:1

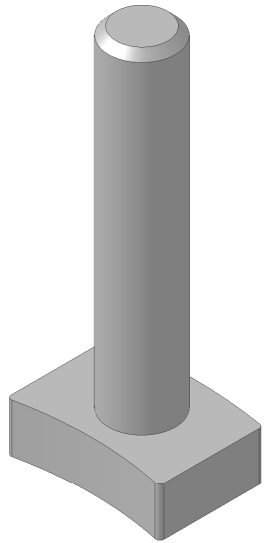
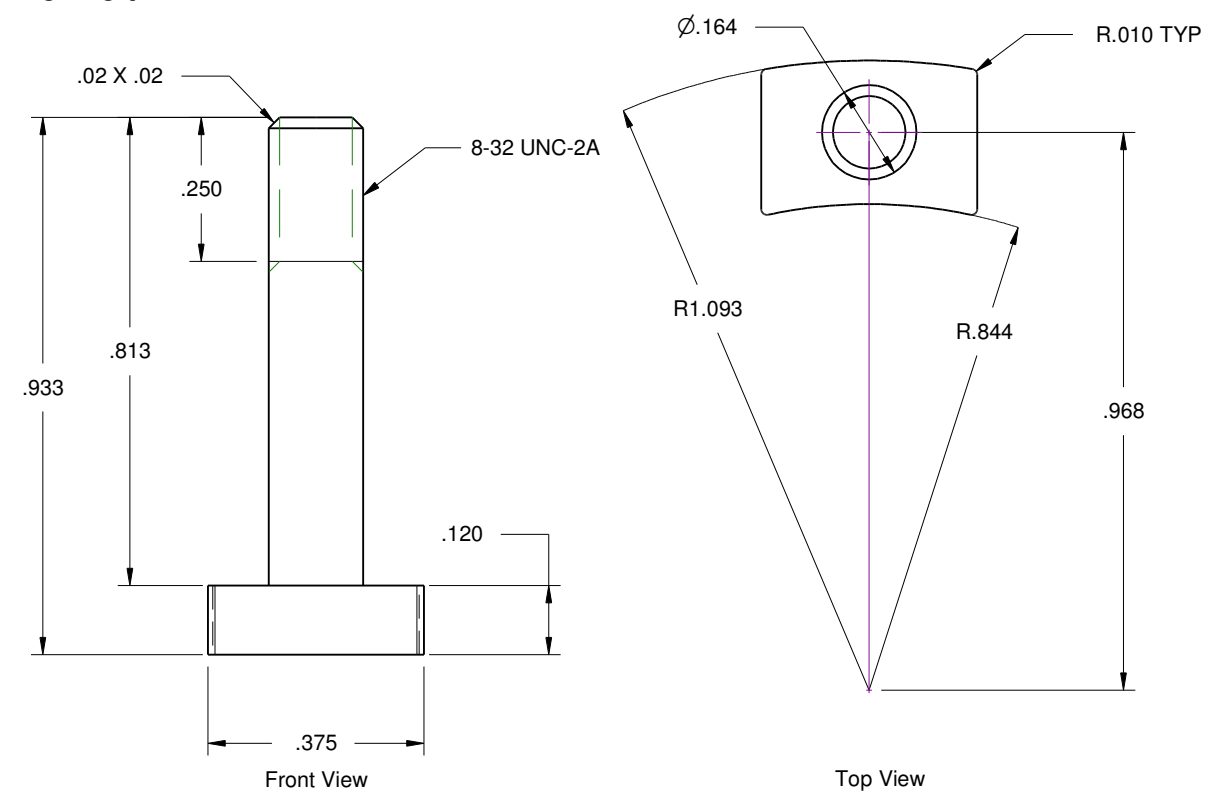

#D15-23 Swivel Nut
Scale 3:1

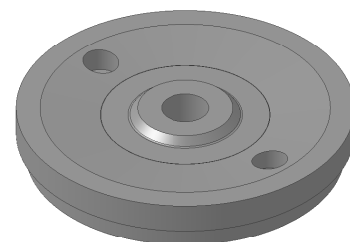
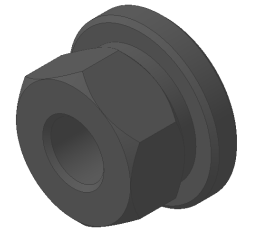
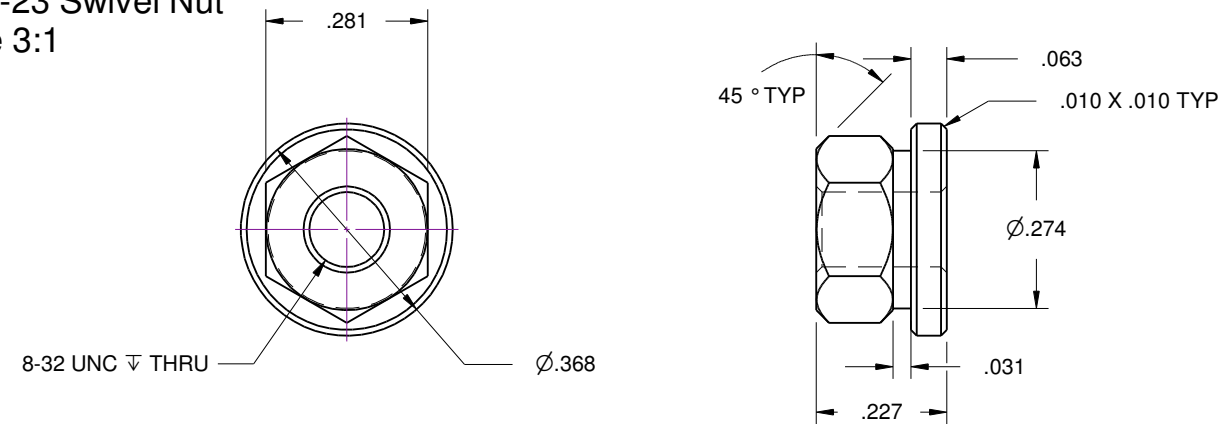

ISO Scale 1:1

MILLVISE

MORRISON & MARVIN ENGINE WORKS

Box 555 Benton City, WA 99320 USA

DESIGNED BY Roland Morrison / Marvin Hedberg		DESCRIPTION Swivel Parts		
DRAWN BY Dave Otto	DATE 1/7/2018	MATERIAL		SCALE
SIZE B		SHEET 13 of 18	REV 1	

#D15-5 Screw
Scale 3:1

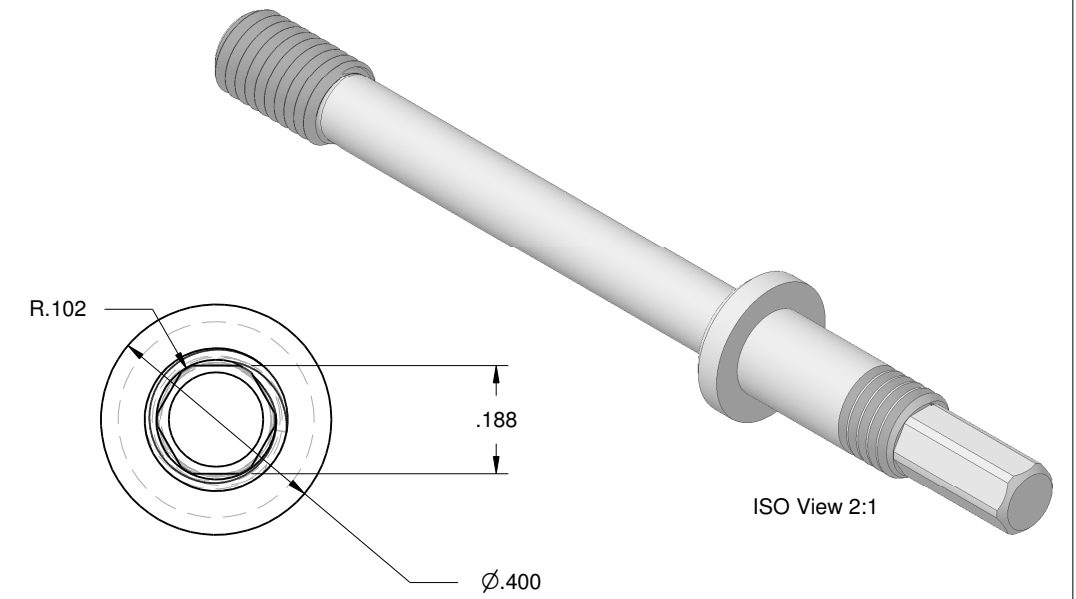
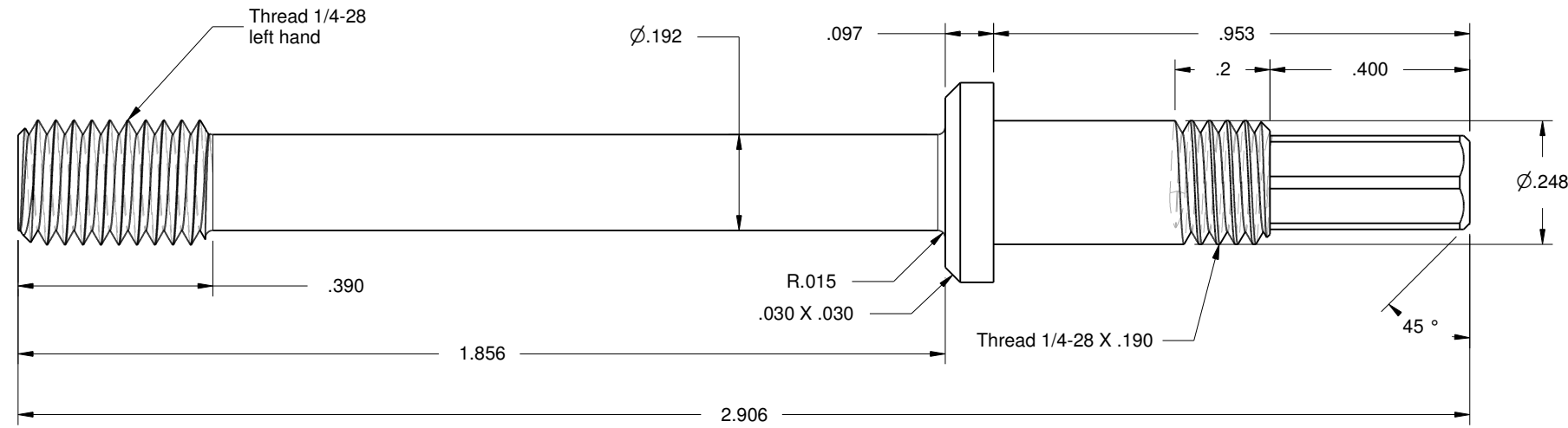

#D15-11 Bearing Race
Scale 3:1
Harden and lap

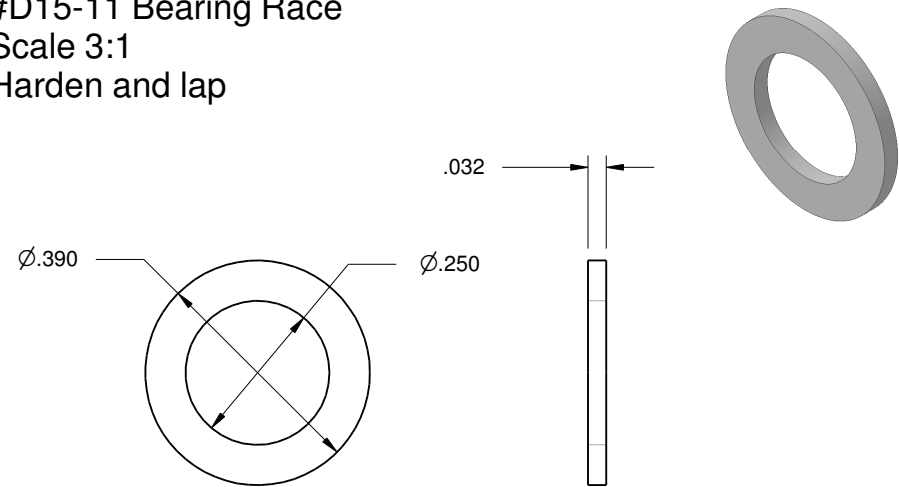

#D15-17 Collar Set Screw Pad
Scale 20:1

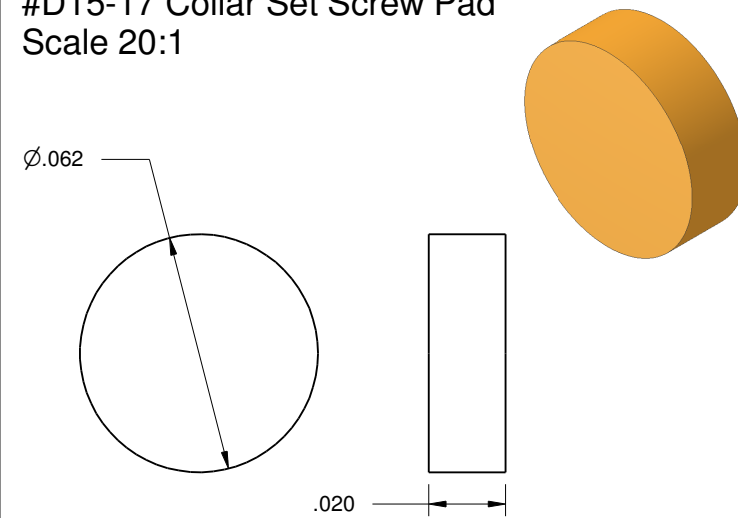

#D15-8 Collar
Scale 3:1

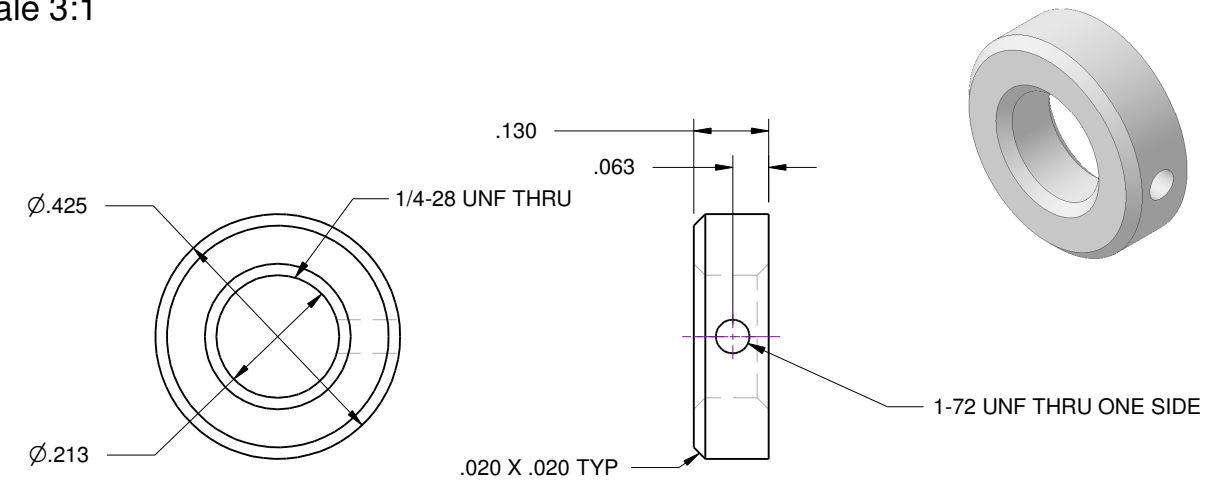

#D15-13 Bearing Cage
Scale 3:1

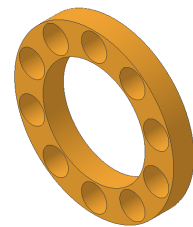
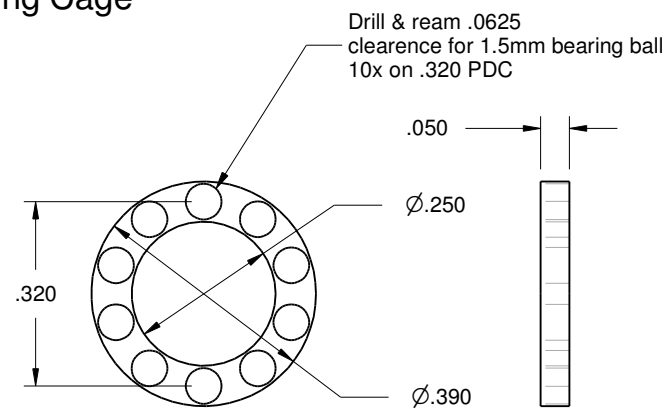

MILL VISE

MORRISON & MARVIN ENGINE WORKS

Box 555 Benton City, WA 99320 USA

DESIGNED BY Roland Morrison / Marvin Hedberg		DESCRIPTION Vise Screw & Parts		
DRAWN BY Dave Otto	DATE 1/7/2018	MATERIAL		SCALE
SIZE B		SHEET 14 of 18		REV 1

Heat treat & temper to 58-60 RC
 If desired leave allowance for
 surface grinding

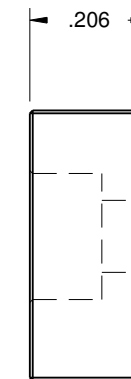
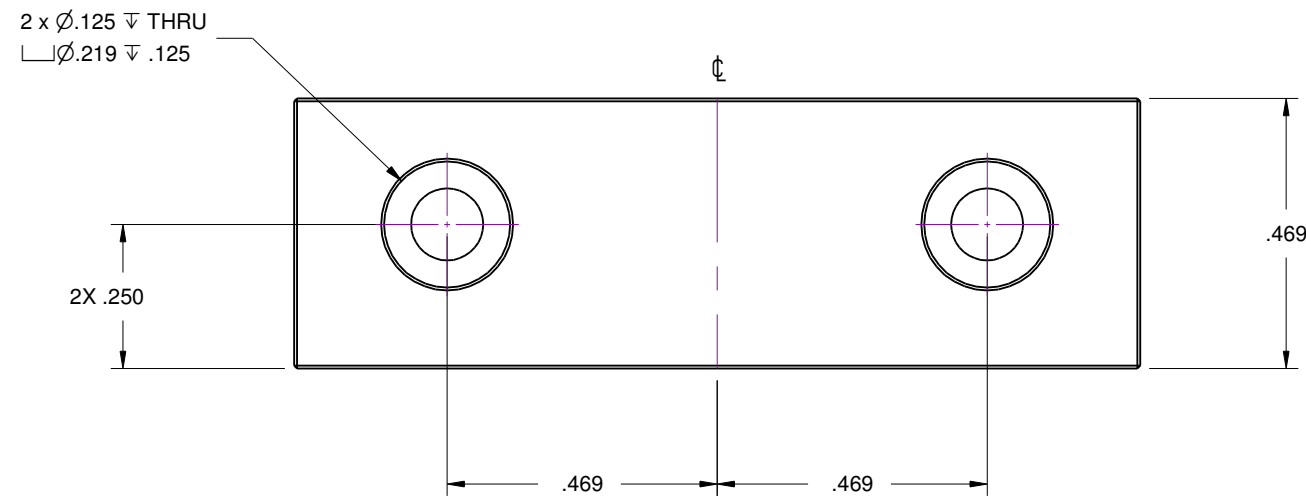
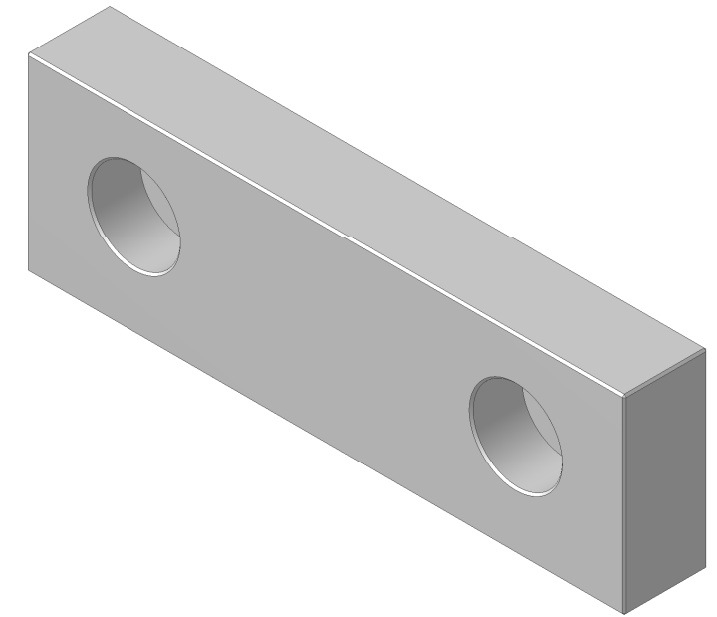
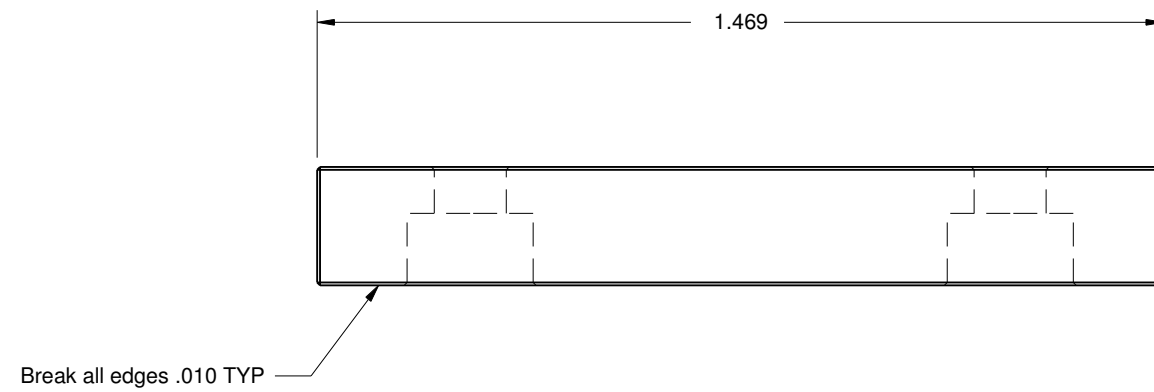

W1 Hardening:

Heat thoroughly at 1425° to 1500° F. Brine Quench.

W1 Tempering:

Tempering Temperature Typical Rockwell C Hardness

As Hardened	66-68
400° F	62-64
500° F	58-59
600° F	54-56

MILL VISE

MORRISON & MARVIN ENGINE WORKS

Box 555 Benton City, WA 99320 USA

DESIGNED BY Roland Morrison / Marvin Hedberg		DESCRIPTION #D15-7 Jaw Plate		
DRAWN BY Dave Otto	DATE 1/7/2018			
MATERIAL W1 Tool Steel	SIZE B	SCALE 3:1	SHEET 15 of 18	REV 1

#D15-24 Handle
Scale 3X

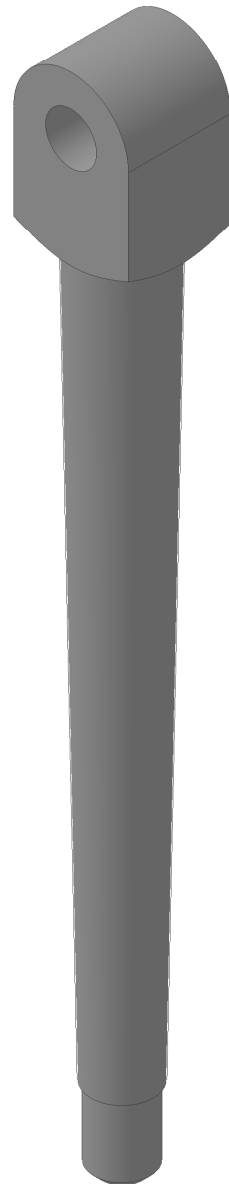
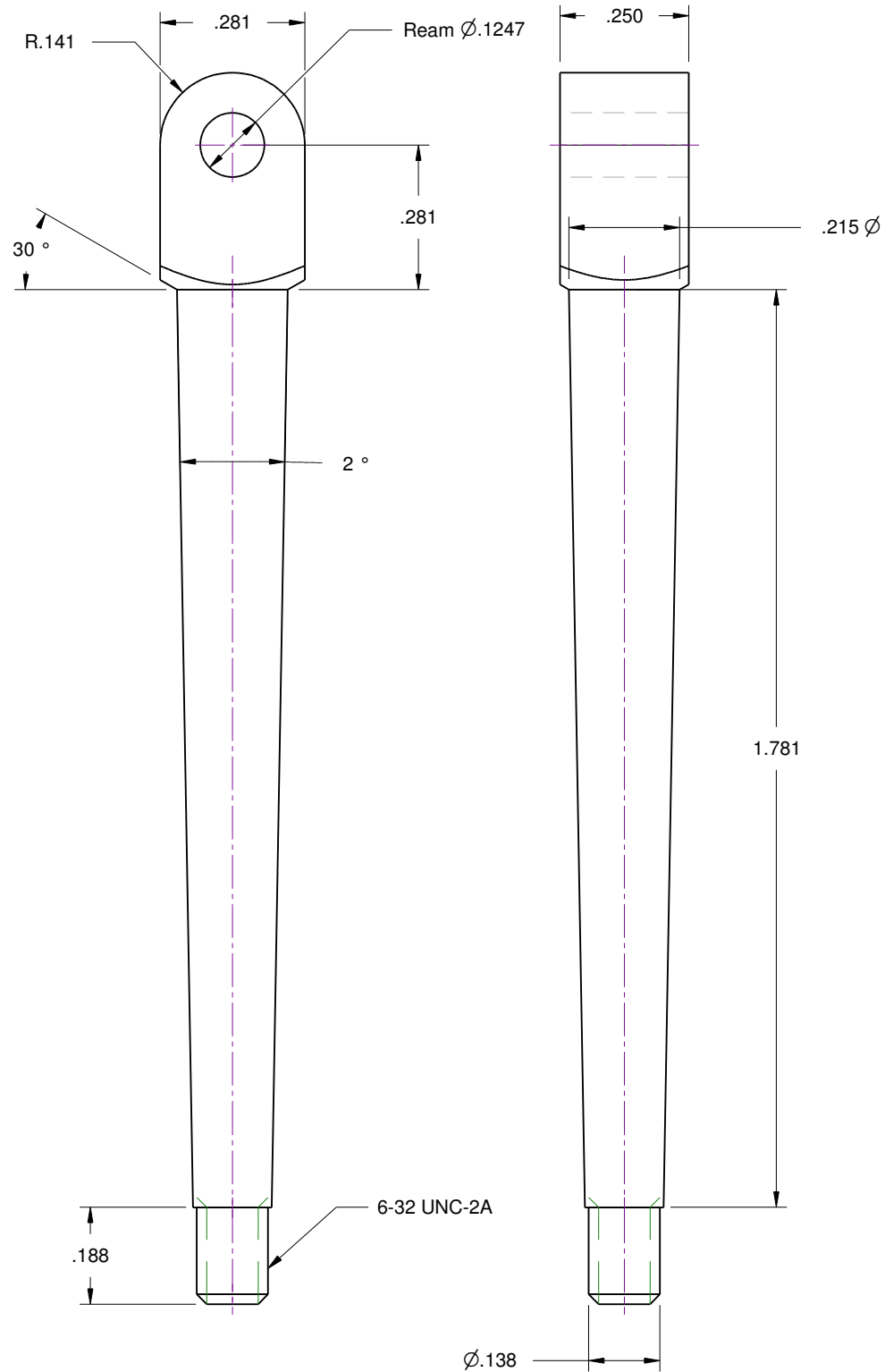

#D15-25 Yoke
Scale 3X

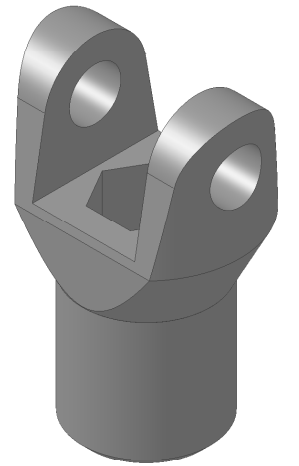
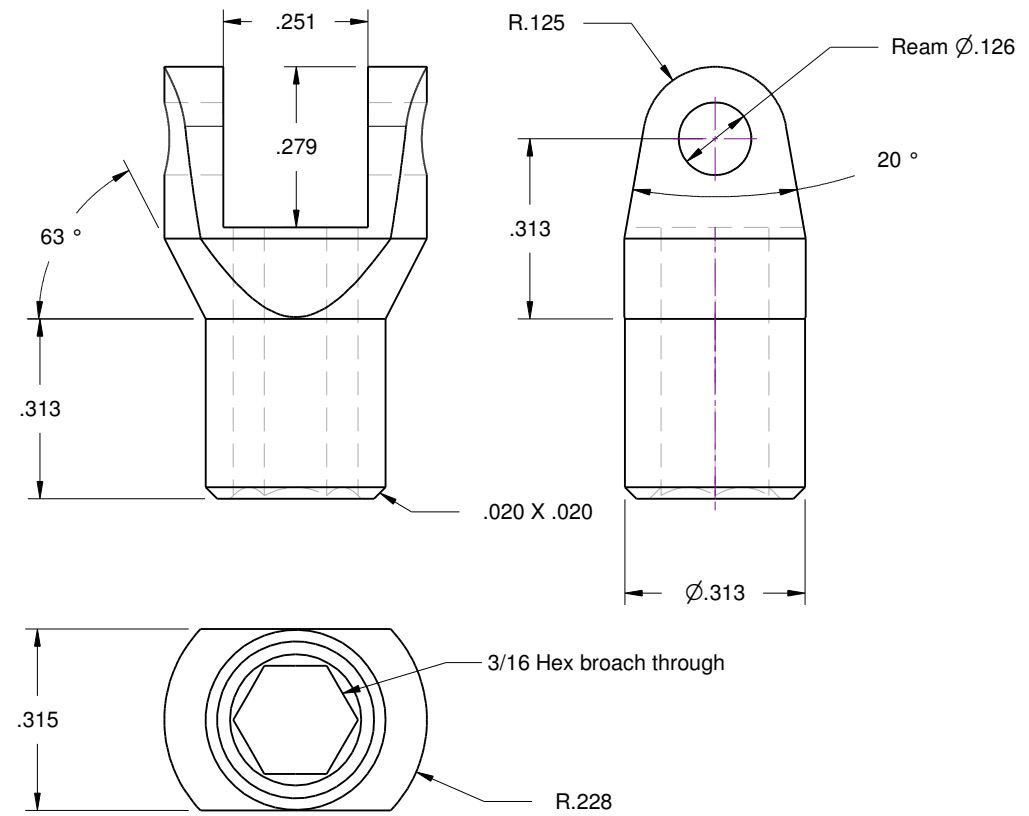

#D15-27 Ball
Scale 3X

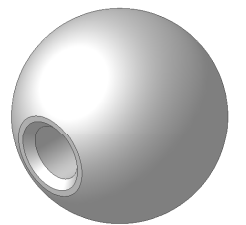
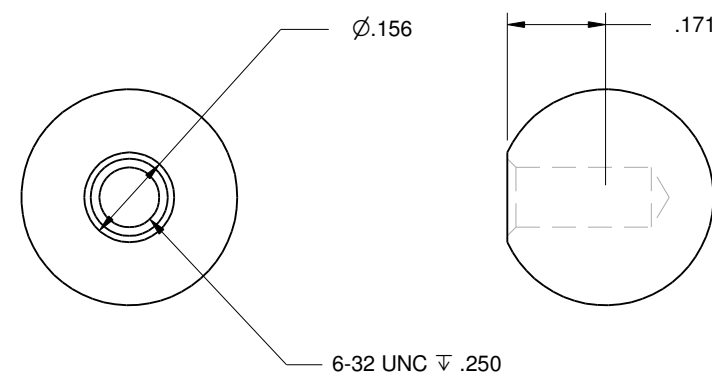

MILLVISE

MORRISON & MARVIN ENGINE WORKS

Box 555 Benton City, WA 99320 USA

DESIGNED BY Roland Morrison / Marvin Hedberg		DESCRIPTION Handle Parts		
DRAWN BY Dave Otto	DATE 1/7/2018			
MATERIAL	SIZE B	SCALE	SHEET 16 of 18	REV 1

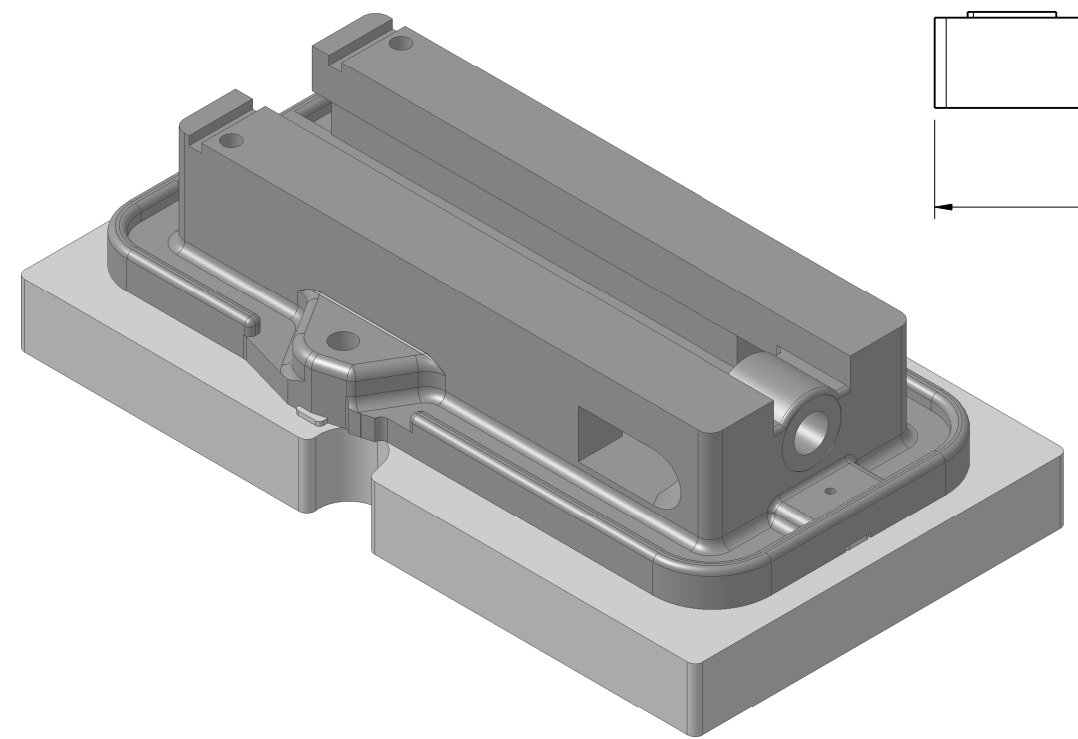
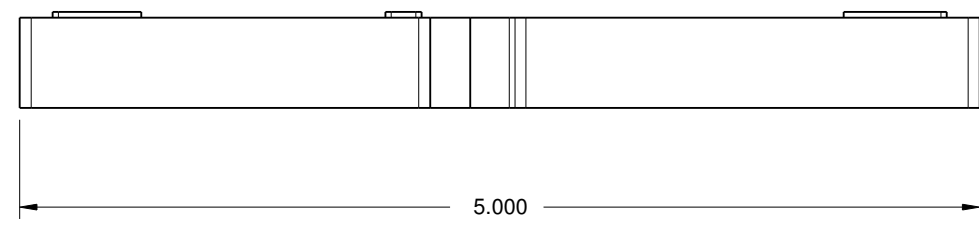
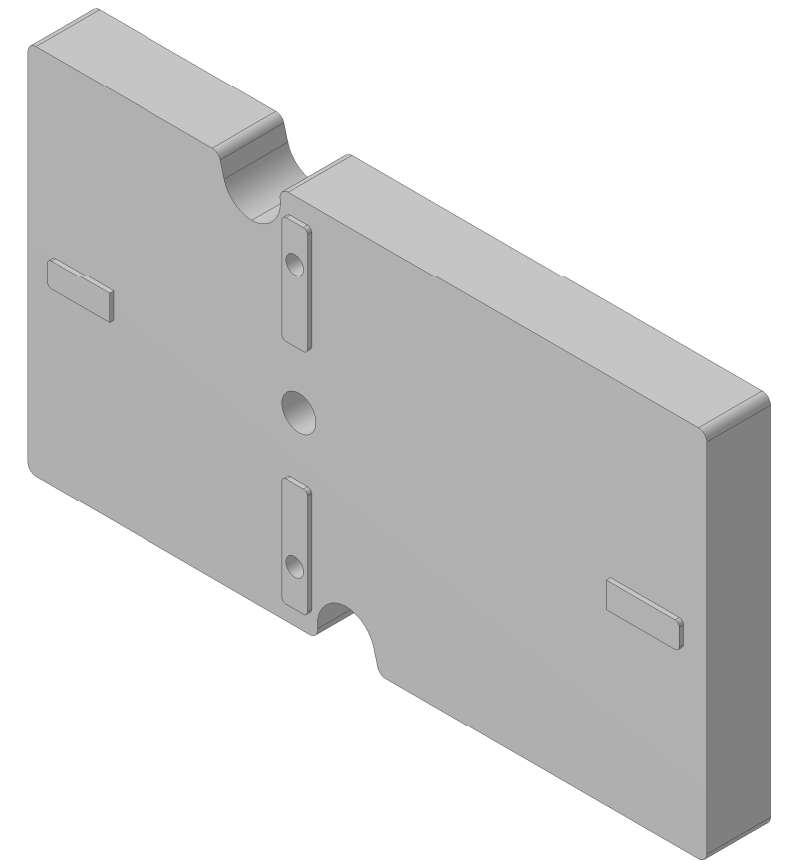
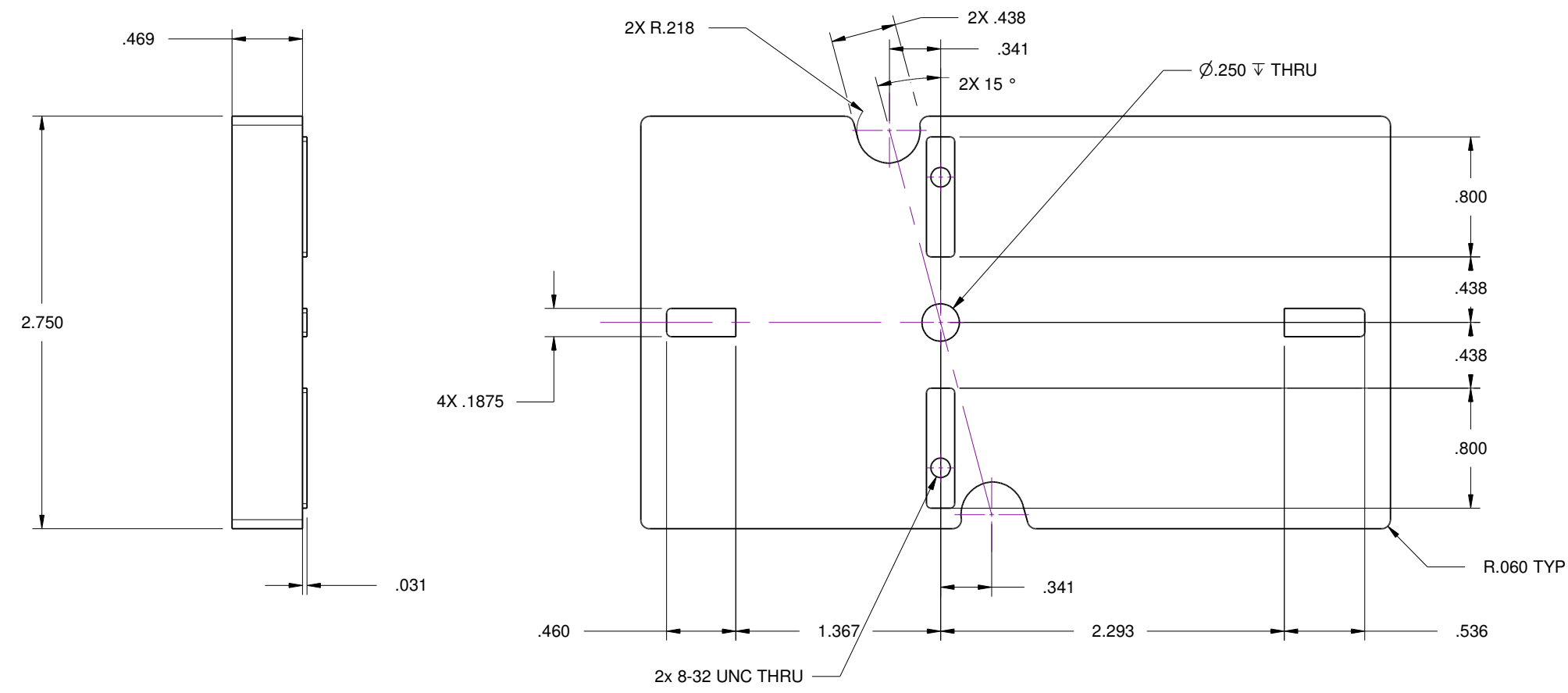

MILL VISE

MORRISON & MARVIN ENGINE WORKS			
Box 555 Benton City, WA 99320 USA			
DESIGNED BY Roland Morrison / Marvin Hedberg		DESCRIPTION Body Machining Fixture	
DRAWN BY Dave Otto	DATE 1/7/2018		
MATERIAL Cast Aluminum Tooling Plate	SIZE B	SCALE 1:1	SHEET 17 of 18
			REV 1

Item Number	Quantity	Part Number	Part Name	Material	Sheet Number
1	1	D15-1	Body	4140	4-5
2	1	D15-2	Movable Jaw	4140	6 & 7
3	1	D15-3	Nut	4140	9
4	1	D15-4	Swivel Base	4140	10-12
5	1	D15-5	Screw	1144	14
6	1	D15-6	Stationary Jaw	4140	6 & 8
7	2	D15-7	Jaw Plate	W1	15
8	1	D15-8	Collar	12L14	14
9	1	D15-9	Spherical Segment	01	7
10	1	D15-10	Dog Point Set Screw	Alloy Steel	
11	2	D15-11	Bearing Race	01	14
12	10	D15-12	Bearing Ball	Alloy Steel	
13	1	D15-13	Bearing Cage	Brass	14
14	1	D15-14	Plastic Cap	Nylon	
15	2	D15-15	Stationary Jaw Screw	Alloy Steel	
16	1	D15-16	Collar Set Screw	Alloy Steel	
17	1	D15-17	Collar Set Screw Pad	Brass	14
18	4	D15-18	Jaw Plate Screw	Alloy Steel	
19	1	D15-19	Swivel Center	12L14	13
20	2	D15-20	Swivel Center Screw	Alloy Steel	
21	1	D15-21	Swivel Pin	Alloy Steel	
22	2	D15-22	Swivel Bolt	12L14	13
23	2	D15-23	Swivel Nut	12L14	13
24	1	D15-24	D15-24 Handle	12L14	16
25	1	D15-25	D15-25 Handle Yoke	12L14	16
26	1	D15-26	D15-26 Handle Pin	Alloy Steel	
27	1	D15-27	D15-27 Handle Ball	Aluminum	16
28	1		Body Machining Fixture	Aluminum	17

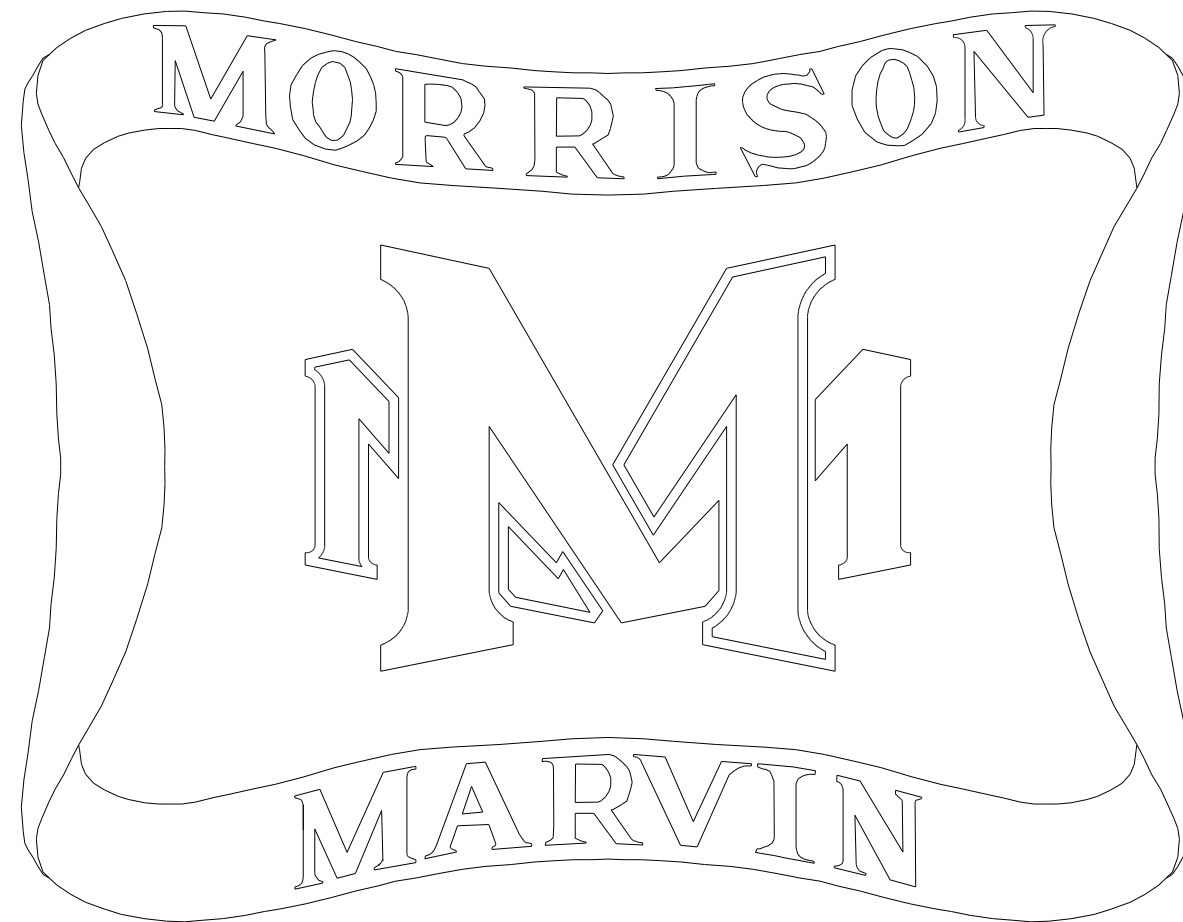

Download a full set of drawings from
MorrisonandMarvin.com

MILL VISE

MORRISON & MARVIN ENGINE WORKS					
Box 555 Benton City, WA 99320 USA					
DESIGNED BY Roland Morrison / Marvin Hedberg			Mill Vise BOM		
DRAWN BY Dave Otto		DATE 1/7/2018			
MATERIAL		SIZE B	SCALE	SHEET 18 of 18	REV 1